

ISUZU

SPECIFICATIONS

NEW
NEW GENERATION ISUZU
GEN

FRR 600-S



AUSTRALIA'S TOP SELLING TRUCK BRAND SINCE 1989. Truck tracker 2007.

AT A GLANCE

GVM	11,000 kg
GCM	16,000 kg
Power	191 kW @ 2,400 rpm
Torque	761 Nm @ 1,450 - 2,400 rpm

ADVANCED TECHNOLOGY

- Driver airbag with seatbelt pretensioner
- Anti-lock Braking System (ABS)
- Anti Skid Regulator (ASR)
- Hill Start Aid (HSA)
- Electric mirrors
- Front stabiliser bar
- ISRI 6860 seat with integrated seatbelt

RELIABILITY IS EVERYTHING **ISUZU**

Driveline & Chassis Specifications

ENGINE: SITEC SERIES II 255 (ISUZU 6HK1-TCC)

- Type:** 6 cylinder 24 valve SOHC
- Displacement:** 7,790 cc
- Compression Ratio:** 17.5:1
- Bore x Stroke:** 115 mm x 125 mm
- Max power** (DIN-NET): 191 kW (256 HP) @ 2,400 RPM
(JIS Gross): 198 kW (265 HP) @ 2,400 RPM
- Max torque** (DIN-NET): 761 Nm (561 lb.ft) @ 1,450 - 2,400 RPM
(JIS Gross): 788 Nm (581 lb.ft) @ 1,450 - 2,400 RPM
- Induction system:** Electronically controlled variable nozzle turbocharger with air-to-air intercooler.
- Fuel injection:** Direct injection high pressure common rail system.
- Emission control system:** Two-stage electronically controlled cooled EGR with exhaust Diesel Particulate Diffuser (DPD). ADR 80/02 (Euro IV) compliant.

CLUTCH

Standard and MW model:

- Air assisted hydraulic control. Single plate 381 mm diameter.
- Total lining area: 1,363 cm²

TRANSMISSION

ISUZU MZX-6P (except MW model)

- 6 speed manual with air assisted shift.
- Synchromesh on gears 2-6. Triple cone synchromesh on 2nd and 3rd gears. Integral oil pump provides full pressure lubrication.
- Gear ratios (: 1)

1st	2nd	3rd	4th	5th	6th	Rev
6.615	4.095	2.358	1.531	1.000	0.722	6.615

ISUZU MLD-6W (MW model)

- 6 speed manual with air assisted shift.
- Synchromesh on gears 2-6.
- PTO provision on LHS of transmission case. PTO drive from counter gear.
- Gear ratios (: 1)

1st	2nd	3rd	4th	5th	6th	Rev
6.120	4.244	2.580	1.540	1.000	0.763	6.525

AXLES

Front: Isuzu F041

- Reverse Elliot I-beam. 4,100 kg capacity.

Rear: Isuzu R077

- Full floating Banjo type. 7,700 kg capacity.
- Drive ratio: 4.100:1

SUSPENSION

Front:

- Single stage alloy steel taper leaf springs.
- Double acting hydraulic shock absorbers. Stabiliser bar.

Rear:

- Multi leaf main spring, multi leaf helper spring.

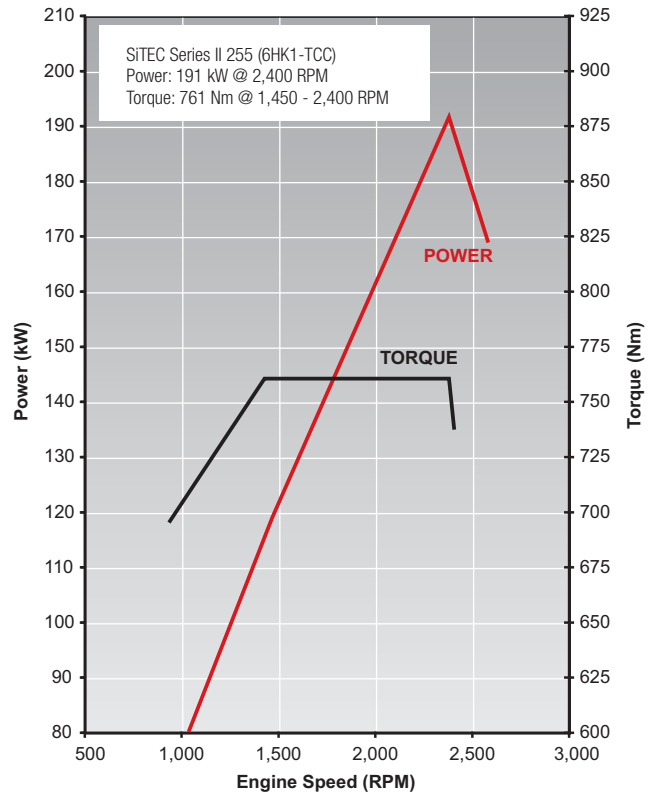

BRAKES

- Dual circuit air over hydraulic front and rear drum brakes.
- ABS.
- ASR traction control.
- Hill Start Aid (HSA).
- Front drum size: 320 x 120 mm
- Rear drum size: 320 x 145 mm
- Spring park brake.
- Air controlled exhaust brake.
- Air dryer.

STEERING

- Power assisted recirculating ball steering.
- Gear ratio: 16:1 - 18.8:1
- Turns lock to lock: 4.1
- Maximum angle: 52° (inside wheel) / 39° (outside wheel)

WHEELS AND TYRES

- 17.5 x 6.00J six stud steel wheels.
- 235/75R17.5 132/130M Michelin XZE2 Tubeless.
- Maximum tyre rating:
 - Steer axle: 4,000 kg
 - Drive axle: 7,600 kg
- Spare wheel and tyre assembly with winch type carrier.

CHASSIS FRAME

- Cold rivetted ladder frame with parallel side rails. HT540A high tensile weldable steel sidemembers.
- Frame dimensions:
 - Side rail (mm): 225 x 70 x 6.0
 - Rear frame width (mm): 840

FUEL TANK

- Frame mounted 200L steel fuel tank.
- Lockable fuel cap.

ELECTRICAL SYSTEM

- 24 volt electrical system.
- 60 amp alternator.
- 24 Volt, 4.5 kW starter motor.
- 2 x 80D26L (630 CCA) batteries connected in series.

Cabin Specifications and Appointments

CAB EXTERIOR

- All steel construction. High tensile steel used for cab underframe. Manual cab tilt to 45° with torsion bar assistance.
- Liquid filled front and rear cab mounts.
- Heavy duty non slip entry steps.
- 90° opening internally reinforced front doors.
- Water spray suppression guards and front mudflaps.
- Laminated windscreen with shade band.
- Two speed windscreen wipers, with intermittent wipe mode.
- Halogen multi-reflector headlamps incorporating turn signals. Additional door mounted side indicator lamps.
- Combination brake, turn, reverse and marker lamps, registration plate illumination lamps. Extended wiring harness. Reverse alarm.
- Roof-mounted clearance lamps.
- Heated and powered exterior main mirrors with flat glass and additional powered convex "spot" mirrors.
- Body coloured grille.
- Body coloured steel air dam bumper with front foglamps.

CAB INTERIOR

- Isri 6860 air suspension driver's seat with pneumatic lumbar support, height, rake and automatic weight adjustment.
- Front passenger adjustable bucket seat and front centre seat with folding seat back.
- 3-point lap sash seatbelts in all outboard seating positions. Driver seatbelt with pre-tensioner integrated with driver seat. Centre seat lap belts.
- Driver airbag.
- Door and roof pillar entry assist grips.
- Full interior trim, padded roof lining and vinyl floor covering. Driver and passenger windscreen header storage shelf.
- Tilt/Telescopic adjustable steering column, soft feel urethane steering wheel.
- Electric windows.
- Central locking with remote keyless entry and immobiliser.
- Twin cup holders. 24V cigarette lighter. Dashboard hook.

- Front door mounted storage pockets and driver's side ashtray.
- Centre console box with storage tray. Fold down storage tray behind centre seat backrest.
- Front passenger glovebox.
- Fully integrated air conditioning and heater/demister with 4-speed fan and outlets for windscreen, side windows, face and floor.
- Fluorescent type interior lamp with On/Door/Off switch.
- 2 DIN, two speaker rado/CD multimedia unit.
- DIN sized compartment for storage or for CB radio installation.

DRIVER CONTROLS

- Key-operated engine start/stop and steering lock. Engine idle speed control.
- HSA slow/fast engagement control and on/off switch.
- ASR on/off.
- DPD regeneration.
- **Left side combination stalk:** Windscreen wipers, washers and exhaust brake.
- **Right side combination stalk:** Turn signals and headlamps.

INSTRUMENTATION

- Electronically driven speedometer and tachometer. Digital odometer with integrated dual tripmeter. Engine coolant temperature, fuel level and air pressure gauges.
- **Warning lamps:** Check engine, oil pressure, ABS, SRS airbag, alternator charge, service brakes, park brake, seat belt unfastened, low air pressure, low fuel level, cab lock.
- **Indicator lamps:** HSA, warm up system, high beam, ASR, DPD status, exhaust brake, turn signals.

OPTIONS AND GENUINE ACCESSORIES

Include the following (extra cost, check with dealer for availability):

- Module for Bluetooth/iPod input/SD card reader.
- Module for Bluetooth/iPod input/SD card reader/satellite navigation (includes NAVTEQ mapping).
- Up to two reversing cameras.
- Airbag compatible bullbar.
- Cloth seat covers.

Weights (kg)

Models	Ratings*		Loading Limit* (at ground)		Cab Chassis Mass#		
	GVM	GCM	Front	Rear	Front	Rear	Total
FRR 600-S Long	11,000	16,000	4,000	7,600	2,270	1,255	3,525
FRR 600-S Long MW	11,000	16,000	4,000	7,600	2,310	1,260	3,570

* Vehicle ratings and front/rear weight limits are subject to government regulatory requirements and weight distribution analysis. Consult your Isuzu dealer to select the correct vehicle for your specific application.

Cab chassis only as supplied and including 10 litres of fuel.

Dimensions (mm)

Models	WB	OAL	FOH	ROH	EA	CE	RT	ORT	CH	FFA (unladen)	RFA (unladen)	RFH (unladen)	Turn Circle (m)
													KERB TO KERB
FRR 600-S Long	5,160	8,605	1,170	2,275	4,175	6,540	1,660	2,175	2,585	715	895	950	16.4

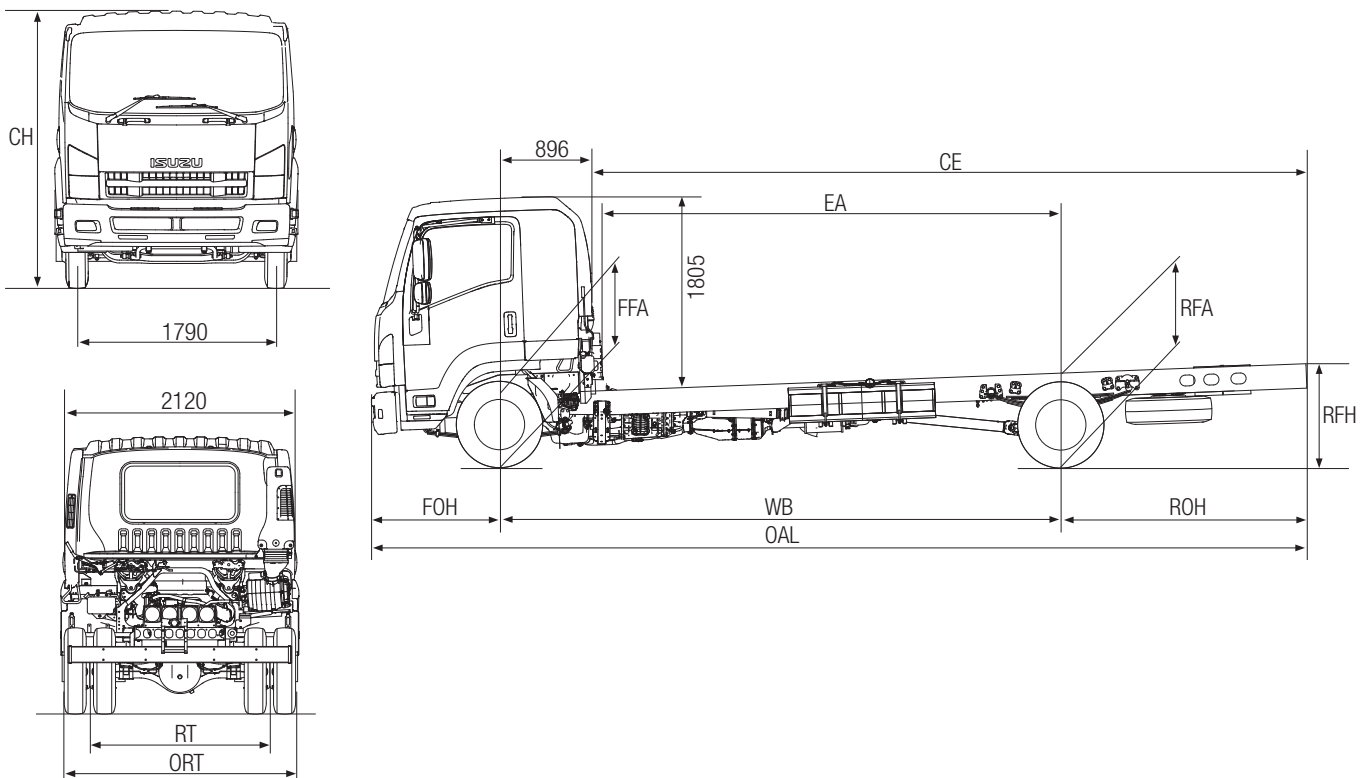

Performance (calculated - typical paved road)

Models	At 11,000 kg GVM	Geared Speed*	Low Speed Gradeability	Engine Speed
		(top gear at peak power engine RPM)	(lowest forward gear assuming no wheel slip)	(top gear at 100 km/h)
FRR 600-S	At 11,000 kg GVM	118 km/h @ 2,400 RPM	44%	2,030 RPM
FRR 600-S MW	At 11,000 kg GVM	112 km/h @ 2,400 RPM	41%	2,145 RPM

* Maximum speed achievable depends on vehicle frontal area as well as other factors. Consult your Isuzu dealer for more detailed information.

Isuzu Warranties

STANDARD ¹		
New Vehicle	3 years 150,000 km 2,500 hrs	
Cab Perforation Corrosion	3 years Unlimited km	
EXTENDED ²		
4 years 250,000 km	5 years 300,000 km	6 years 350,000 km

Order Codes

Model	Code
FRR 600-S Long	FH-FRRCH-D01
FRR 600-S Long MW	FH-FRRCH-X01

¹ Subject to the conditions outlined in the IAL New Vehicle Warranty, the Isuzu FRR model carries a standard factory warranty which covers the owner: (i) for the entire vehicle, for the first 36 months or 150,000 km or 2,500 hrs (whichever comes first). (ii) against cab perforation corrosion, for 36 months and unlimited kilometres. ² Extended Warranty as illustrated is available by purchase to cover the owner against the failure of original components, but may exclude some components and expendable items such as oil, filters, etc. Please consult with your Isuzu Dealer for full details obtained from a dedicated brochure available to customers.

ISUZU AUSTRALIA LIMITED ABN 97 006 962 572 ("IAL"). The information in this brochure was correct at time of printing, but all measurements, specifications and equipment are subject to change without notice. Some equipment may have been changed and/or is available at extra cost. IAL may make changes at any time without notice, in prices, colours, materials, equipment and models. IAL makes all reasonable attempts to ensure the availability of all vehicles and equipment. The information in this brochure is general in nature. Your Isuzu dealer can confirm all measurements, specifications and vehicle / equipment availability upon request.

July 2008. ARK0330