

1400

FVM 1400 6 x 2

GVM 22,500 kg
GCM 30,000 kg
WHEELBASE 5,650 mm

ISUZU 6SA1-T ENGINE PERFORMANCE

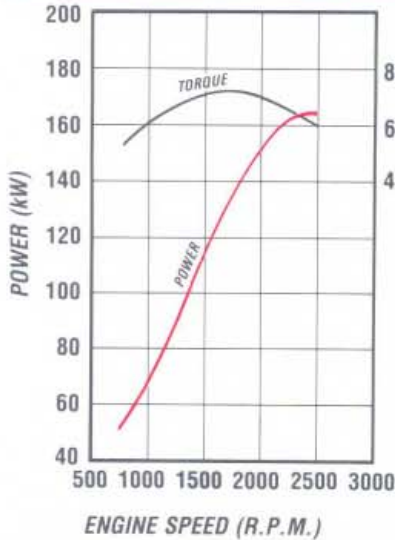

- Type: 6 Cylinder Turbocharged Diesel, four stroke, overhead camshaft, direct injection
- Bore x Stroke (mm) 115 x 135
- Displacement 8413 (cc)
- Compression ratio (:1) 16.3
- Output-Power (kW) 163 @ 2500 rpm (DIN Nett)
- Torque (Nm) 735 @ 1700 rpm (DIN Nett)

DIMENSIONS

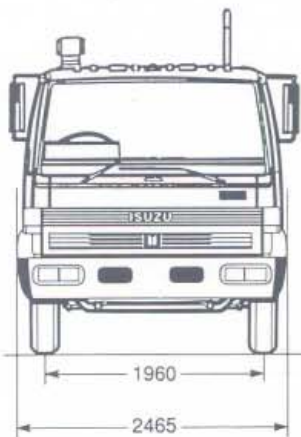
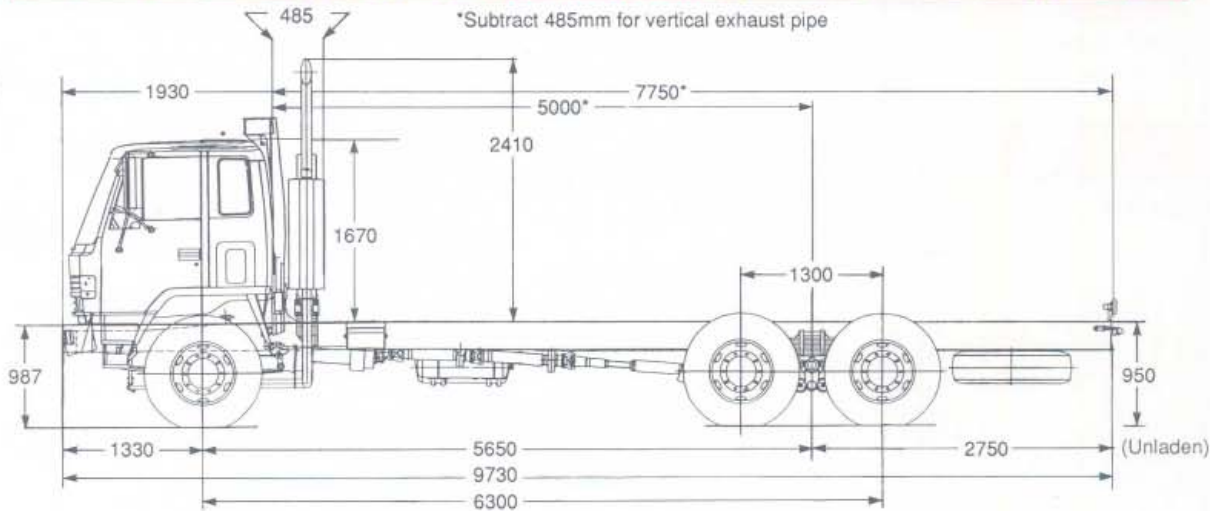

*ESTIMATED KERB MASS (kg)	
FRONT	3120
REAR	3360
TOTAL	6480
FRAME WIDTH (mm)	
	850
TURNING CIRCLE (m)	
kerb to kerb	21.0
BODY LENGTH (mm)	
	7620
Subject to weight distribution	

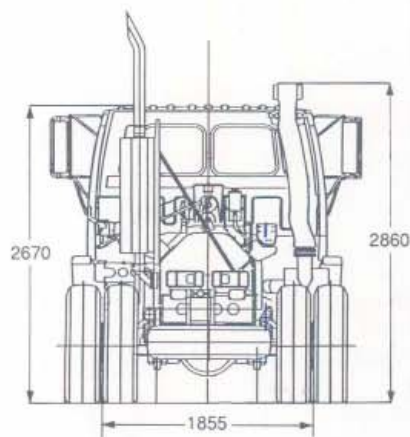

*Chassis and cab with oil, water and fuel tank containing 10 litres of fuel.

ISUZU-GENERAL MOTORS AUSTRALIA LTD A.C.N. 006 962 572

12/50 WARRANTY. Every Isuzu Truck is covered by the I-GM new vehicle warranty which covers your vehicle for the first 12 months or 50,000 kilometres.

PLEASE NOTE: as the policy of Isuzu-General Motors Australia Motors is one of continual product improvement, all specifications and equipment are subject to change without notice. Body illustrated are not standard. No I-GM dealer or other person is authorised or permitted to give or make any statement, assertion or undertaking in relation to the quality performance characteristics descriptions or fitness for any purpose of any I-GM product or in connection with the supply of any I-GM product which is at variance with any written statement assertion or undertaking on any of these subjects given or made by Isuzu-General Motors Australia Limited in its published sales literature, and the company accepts no liability for any such unauthorised action. Isuzu-General Motors Australia Limited has franchised dealers in many parts of Australia. For the sale of service parts and the provision of service to owners of I-GM products. Every endeavour is made to ensure that such dealers carry adequate stocks of service parts, and are equipped to provide satisfactory service, but makes no promise, other than that contained in the New Vehicle Warranty given by Isuzu-General Motors Australia Limited, that such parts or service facilities will be available, or available at any specific location or any particular time.

CT2932-10/91

ISUZU





1400

FVM 1400 6 x 2

ORDERING CODE
8EV02-753

ENGINE - ISUZU 6SA1-T

Lubrication:

- Pressure feed lubrication with full flow paper element filter, oil cooler. Oil capacity 16.6 litres including filter.

Cooling System:

- Six blade plastic cooling fan with thermatic clutch, size 520 mm diameter.
- Tube and corrugated fin pressure type radiator. Size (mm) 682h x 559w x 80t. Frontal area 0.393 m² with bell mouth fan shroud.

FUEL SYSTEM

- Two stage paper element air cleaner, Donaldson 13" with high vertical air intake stack and rain head.
- In line plunger, Bosch 'AD' type fuel injection pump with mechanical all speed governor.
- In line paper filter, see through water separator with drain cock.
- Fuel tank capacity 200 litres.
- Vertical exhaust muffler, mounted on independent gantry with heat shield.

CLUTCH

- Hydraulic control, dry single plate with 6 coil type cushioning springs, 380 mm diameter. Lining area 1362 cm², torque capacity 735 Nm.
- Air servo assistance.

TRANSMISSION FULLER ROADRANGER RT6610

- 10 speed, direct drive, range change. Oil capacity 6.0 litres.

Gear Ratios:1

1st	8.94	7th	2.05
2nd	7.00	8th	1.60
3rd	5.46	9th	1.25
4th	4.26	10th	1.00
5th	3.42	RH	2.78
6th	2.61	RL	9.50

- Maximum geared speed 99.6 km/h.
- Three piece propeller shaft, 101.6 mm diameter.

Length:	1st section	837 mm
	2nd section	836 mm
	3rd section	1097 mm

REAR AXLE - CAPACITY 16,500 kg

- Banjo type, fully floating, single reduction.
- Tandem/single drive with tag lazy axle
- Ratio: 4.875:1.
- Hypoid type ring gear: 440 mm diameter
- Oil capacity: 14 litres

REAR SUSPENSION - CAPACITY 28,000 kg

- Isuzu 6 rod type with semi-elliptical alloy steel multi-leaf springs.
- Size - length x width x thickness:
1300 x 80 x 20 mm - 10 leaves

FRONT AXLE - CAPACITY 6,000 kg

- Reverse Elliot I-beam type. King pin diameter 50 mm with cylindrical roller thrust bearing.

FRONT SUSPENSION - CAPACITY 7,200 kg

- Semi elliptical, alloy steel, tapered, multi-leaf springs. Fully wrapped eye with greasable shackles.
- Size - length x width x thickness:
1470 x 80 x 12 mm - 2 leaves
1470 x 80 x 14 mm - 5 leaves
- Stabiliser bar.
- Hydraulic, double acting, telescopic shock absorbers.

STEERING

- Fully integral, power assisted, recirculating ball type. Gear ratio 22.4:1. Number of turns lock to lock 5.4.
- Gear driven vane type oil pump, oil capacity 2.5 litres.

BRAKES

- Full air, S cam, dual circuit, front and rear leading and trailing.
- Drum diameter 410 mm, front and rear. Total lining area 8280 cm².
- Air tank capacity 85.9 litres. Automatic air drain valve.
- Compressor bore x stroke 85 x 60 mm, driven at half engine speed.
- Spring parking brake acting on rear wheels, with emergency release.
- Butterfly air controlled exhaust brake system, activation switch on wiper/washer control stalk.

CHASSIS FRAME

- Parallel rail, ladder type, channel section, cold riveted.
- Side member dimensions - 254 x 85 x 8 mm
- Frame reinforcement L section 220 x 77 x 4.5mm at back of cab.
- High tensile steel, HT55 weldable frame material.

WHEELS AND TYRES

- 8.25 T x 22.5 - 10 stud disc wheels front and rear, 22 mm bolt size.
- 11 R 22.5 - 16 ply tubeless radial tyres. Front, rear and spare - Goodyear G291, number of tyres 11, including spare.
- Winch type spare wheel carrier.

ELECTRICAL SYSTEM

- Batteries 2 x 12 volt - 55 Amp/h, negative earth.
- Alternator 24 volt - 40 Amp.
- Starter motor 24 volt - 5.5 kW output.
- Rear stop and tail lamps and licence plate lamp with long leads for variable body mounting. Turn signal side indicator lamps for body mounting.

CAB EXTERIOR

- All steel cab, manual tilt to 45°. Cation electro deposition primer. Torsion bar counter balanced.
- Heavy duty bumper bar with four rectangular halogen headlamps inset.

- Access to engine fluid checks without tilting cab.
- Combination turn signal and park lamps.
- West Coast type rear view mirrors with clearance lamps.
- Laminated windshield, 2 speed wiper with intermittent mode and washers.
- Front and rear quarter vent windows.
- Corrosion resistant, non-slip, cab entry steps.
- Tool kit with 10,000 kg capacity jack.

CAB INTERIOR

- Fully trimmed cab interior with cloth seat facings, formed roof lining and overhead parcel shelf with driver and passenger sun visors.
- ISRI 5000 driver's seat with mechanical suspension, adjustment for seat back recline, seat slide and height control.
- Outboard passenger seat, folding centre seat back with lockable compartment and snack tray.
- Outboard lap/sash seat belts with emergency locking retractor, inboard lap seat belt.
- Tilt telescopic adjustable steering column, soft feel urethane steering wheel.
- Easy entry grab handles on 'A' and 'B' pillars.
- Heater demister with 4 speed fan, 4 outlets to screen, 5 fascia outlets, 5 foot outlets.
- AM/FM radio with digital clock, dash mounted.
- Park brake activation level beside driver's seat.
- Engine cover mounted gear shift lever.

INSTRUMENTATION

- Speedometer, odometer and tachometer.
- Gauges for coolant temperature, fuel level and brake air pressure.
- Dash illumination control.

INDICATOR LAMPS

- Turn signals, parking brake on, high beam on, exhaust brake engaged.

WARNING LAMPS

- With warning bulb check switch.
- Battery charge, oil filter clogged, oil pressure, low air pressure, air cleaner clogged, stop and tail lamp failure.

SWITCHES

- Left side combination switch for exhaust brake, wipers and washers.
- Hazard lamp switch.
- Right side combination switch for headlamps, turn signals and headlamp dip.
- Key operation for engine stop and start, external engine crank switch for service when cab is tilted.
- 24 Volt 2 pin accessory plug on centre fascia.
- Three way switch for interior lamp activated by driver and passenger doors.
- Control for emergency park brake release.