



# ISUZU FVR 11NT CUSTOM

GMH MODEL: FVR 11NT	STANDARD GVM	13900 kg
ORDERING CODE: 8DK 03	TARE MASS (estimated)	4665 kg
	STANDARD GCM	22500 kg

## DRIVELINE SPECIFICATION

### ENGINE

Model: ISUZU 6BD1-T  
 Type: 6 cylinder Turbo charged diesel  
 Displacement: 5785cc  
 Max power: 127kW @ 3000 rpm  
 Max torque: 470 Nm @ 2000 rpm  
 Bore & Stroke 102 x 118mm  
 Compression ratio: 170:1  
 RAC Rating: 38.7

### TRANSMISSION

Model: ISUZU MBG5F  
 Type: 5 speed direct drive  
 Gear ratios (to 1)  
 1st 6.890  
 2nd 3.918  
 3rd 2.121  
 4th 1.165  
 5th 1.000  
 Rev 5.411

### AXLE, FRONT

Type: Reverse Elliot I beam  
 Capacity: 6000 kg

### AXLE, REAR

Type: Banjo fully floating. Eaton two speed  
 Capacity: 10500 kg  
 Ratio: 5.571/7593:1

### BRAKES:

Air over hydraulic

### WHEELBASE:

5500mm

## CHASSIS RATINGS

GROSS COMBINATION and GROSS VEHICLE MASS RATING				Estimated kerb mass (chassis and cab with oil, water and full fuel tank). (kg)		
	GVM (kg)	GCM (kg)	Tyres	Front	Rear	Total
Std	13900	22500	10.00 x 20-14ply front 10.00 x 20-12 ply rear	2620	2045	4665
Opt	13900 13900	22500 22500	10.00 x 20-14ply front & rear 10.00R x 20-14ply			

## DIMENSIONS

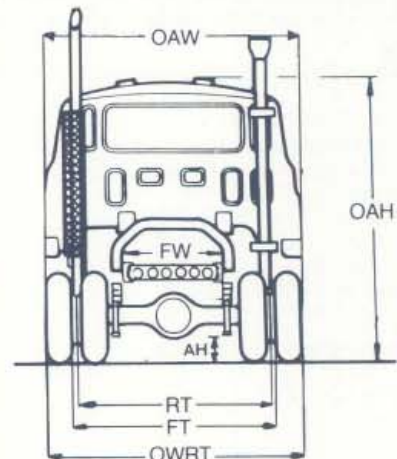
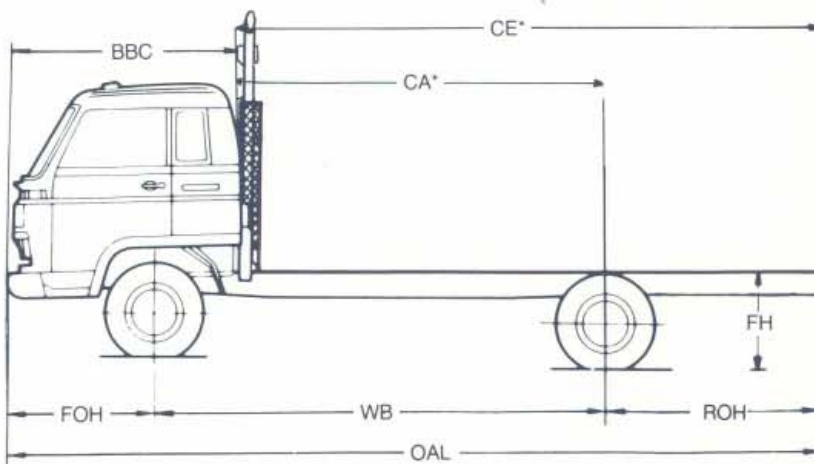

### LENGTHS:

Overall length	OAL	(mm)	9210
Wheelbase	WB		5500
Cab to axle	CA*		4850
Cab to end of frame	CE*		7300
Front Overhang	FOH		1260
Rear Overhang	ROH		2450
Bumper to back of cab	BBC		1910

### WIDTHS

Overall width	OAW		2370
Frame width	FW		850
Front track	FT		1960
Rear track	RT		1855
Outside width rear tyres	OWRT		2460

### HEIGHTS

Overall height	OAH	2570
Ground to top of frame	FH	1020
Axle clearance	AH	245

### TURNING CIRCLE

Kerb to kerb	(m)	19.0
Wall to wall		20.4

\*CA & CE dimensions are effectively reduced by 300mm with fitment of vertical exhaust pipe and protector.



# ISUZU

Reliability is everything.

# ISUZU FVR 11NT CUSTOM

## CAB/CHASSIS COMPONENT SPECIFICATIONS

### AXLE, FRONT

Type: Reverse Elliot I beam  
Capacity: 6000 kg

### AXLE, REAR

Type: Banjo fully floating. Eaton 2 speed  
Capacity: 10500 kg  
Ratio: 5.571/7593

### BRAKES, SERVICE

Type: Air over hydraulic. Dual circuit. Front two leading rear dual two leading. Exhaust brake

### BRAKE, PARKING

Type: Spring brake acting on rear wheels.

### STANDARD CABIN EXTERIOR

All steel tilt cab with laminated windshield. 2 speed windshield wiper/washer with intermittent setting. West-coast type rear view mirrors. Dual round sealed beam headlamps.

Vertical air intake stack. General hand tools and

7000kg capacity jack. Spare wheel and tyre.

### INTERIOR

Custom cab interior. Adjustable driver's suspension seat with adjustable lumbar support. Tilt telescopic adjustable steering wheel. Adjustable roof vents. Rear side vent windows. Passenger bucket seat and second passenger centre seat which lifts up for coolant and oil check. AM Radio. Heater/demister with 4 speed fan. Driver and passenger sunvisors. Suspended roof lining.

### INSTRUMENTATION

Speedometer and odometer. Tachometer. GAUGES for engine temperature, brake air pressure and fuel level. INDICATOR LAMPS for turn indicators, headlamp high beam, exhaust brake on and park brake on. WARNING LAMPS for low brake fluid, low brake air pressure, battery charge, clogged air filter, oil pressure. Left side combination switch for exhaust brake & two speed wipers with intermittent setting. Hazard warning switch. Fog lamp switch. Right combination switch for headlamps, turn signal and headlamp dip. Key operation auto engine stop.

### CLUTCH

Type: Dry single plate with cushioning springs, hydraulic control.

Size: 350mm diameter.

### ENGINE SPECIFICATION

Type: 6 cylinder turbo charged diesel

Displacement: 5785cc

Max. Power: 127 kW @ 3000 rpm

Max. Torque: 470 Nm @ 2000 rpm

Bore and Stroke 102 x 118 mm

Compression ratio: 17.0:1

RAC rating: 38.7

YOUR GMH ISUZU DEALER:

### LUBRICATION

Pressure feed with full-flow paper element filter & partial filter oil cooler

Capacity 175 litres including filters.

### COOLING

Heavy duty radiator. Tube and corrugated fin.

Size: 622 length x 559 width x 53 depth.(mm)

Frontal area: 0.348m<sup>2</sup>

### AIR CLEANER

Donaldson cyclopac 11" single stage type. Long vertical air intake stack.

### FUEL SYSTEM

Injection pump Bosch A in-line with mechanical all speed governor. Fuel/water sedimentor, pre-fuel filter.

Fuel tank capacity: 200 litres

### ELECTRICAL SYSTEMS

Batteries: 2 x 12 volt 53 A/H

Alternator: 24 volt — 25 Amp

Starter: 24 volt — 4.5 kW

### FRAME

Type: Ladder type channel section

Side member dimensions: depth x width x thickness (mm)

254 x 85 x 8

### STEERING

Type: Power assisted recirculating ball.

Gear Ratio: 22.4:1

### SUSPENSION, FRONT

Type: Semi-elliptical alloy steel leaf springs

Shock absorbers: Hydraulic double acting telescopic

### SUSPENSION, REAR

Type: Semi-elliptical alloy steel leaf springs

### TRANSMISSION

Type: 5 speed direct drive

Gear ratios (to 1)

1st 6.890 2nd 3.918 3rd 2.121 4th 1.165

5th 1.000 Rev 5.411

### TYRES AND WHEELS

Tyre size: 10.00 x 20 — 14 ply front, 12 ply rear.

Wheel type and size: 750V x 20, 10 stud disc wheels

### GMH 12/20 WARRANTY

Every Isuzu is covered by the GMH warranty which covers the vehicle for the first 12 months or 20,000 kilometres.

Major engine components and driveline components have additional extended warranty. Please consult your GMH/ISUZU dealer for complete and accurate details.

PLEASE NOTE: As the policy of General Motors-Holden's is one of continual product improvement, all specifications and equipment are subject to change without notice. Bodies illustrated are not standard.

No GMH Dealer or other person is authorised or permitted to give or make any statement assertion or undertaking in relation to the quality performance characteristics descriptions or fitness for any purpose of any GMH product or in connection with the supply of any GMH product, which is at variance with any written statement assertion or undertaking on any of these subjects given or made by General Motors-Holden's Limited or General Motors-Holden's Sales Pty. Ltd. in its published sales literature, and neither company accepts any liability for any such unauthorised action.

General Motors-Holden's Limited and General Motors-Holden's Sales Pty. Ltd. have franchised dealers in many parts of Australia for the sale of service parts and the provision of service to owners of GMH's products. Every endeavour is made to ensure that such dealers carry adequate stocks of service parts, and are equipped to provide satisfactory service, but neither General Motors-Holden's Ltd. nor General Motors-Holden's Sales Pty. Ltd. makes any promise, other than that contained in the New Vehicle Warranty given by General Motors-Holden's Sales Pty. Ltd., that such parts or service facilities will be available, or available at any specific location or any particular time.

General Motors Holden's Sales Pty. Ltd.



# Reliability is everything.