

ISUZU FVR 900 LONG

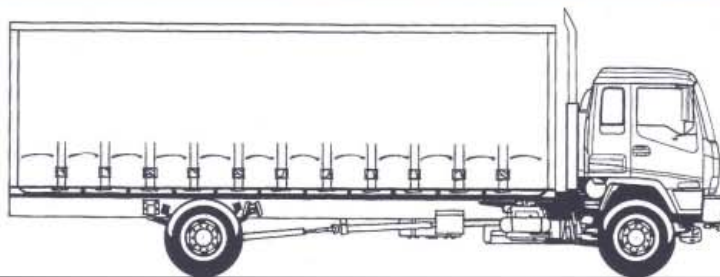

ENGINE ISUZU 6HH1-S

- Type:** 6 cylinder, overhead camshaft, 4 stroke, direct injection, diesel.
- Bore x Stroke:** 115 mm x 132 mm.
- Displacement:** 8226 cc.
- Compression Ratio:** 18.5 : 1.
- Output - Power:** 150 kW @ 2850 RPM. (ISO 1585)
- Torque:** 539 Nm @ 1700 RPM. (ISO 1585)

CLUTCH

- Hydraulic control dry single plate. 352 mm (14") diameter.
- Asbestos free lining material. Total lining area (both sides) 1164 cm².

TRANSMISSION ISUZU MLD6E

- 6 speed direct drive, constant mesh with synchromesh on gears 2-6. Oil capacity 6.5 litres.
 - Gear ratios (: 1)
- | | | | | | | |
|-------|-------|-------|-------|-------|-------|-------|
| 1st | 2nd | 3rd | 4th | 5th | 6th | Rev |
| 8.181 | 5.167 | 3.333 | 2.105 | 1.347 | 1.000 | 8.307 |
- Maximum geared speed 98km/h.
 - 3 piece propeller shaft, 90 mm diameter.

REAR AXLE ROCKWELL RS23160 CAPACITY 10500 KG

- Banjo type, fully floating, single reduction. Ratio 5.625 : 1.
- Hypoid type ring gear. 457 mm diameter. Oil capacity 15.0 litres.

BRAKES

- Rockwell 'Q Plus' full air 'S' cam dual circuit, front and rear leading and trailing shoes. Drum diameter front and rear 419 mm. Total swept area 8688cm².
- Asbestos free lining material.
- Air tank capacity 67.5 litres.
- Spring park brake acting on rear wheels.

MODEL	WHEELBASE	GVM	GCM	ORDERING CODE
FVR 900 LONG	6050mm	16000kg	24000kg	8FR02-971

KERB MASS (kg)*

	Front	Rear	Total
FVR 900 LONG	2,860	2,125	4,985

*Estimated mass of chassis cab with oil, water and fuel tank containing 10 litres of fuel. Excluding spare wheel and tools.

DIMENSIONS (mm) *

	FVR 900 LONG
Wheelbase (WB)	6,050
Overall Length (OAL)	10,020
Rear Overhang (ROH)	2,700
Cab To Axle (CA)	5,340
Cab To End Of Frame (CE)	8,040
Front Frame Height, Unladen (FFH)	990
Front Frame Height, Laden (FFL)	941
Rear Frame Height, Unladen (RFH)	1,050
Rear Frame Height, Laden (RFL)	951
Turning Circle (Kerb To Kerb)	22.5m
Nominal Max. Body Length*	8,395

*Except Turning Circle: metres. *Subject to weight distribution

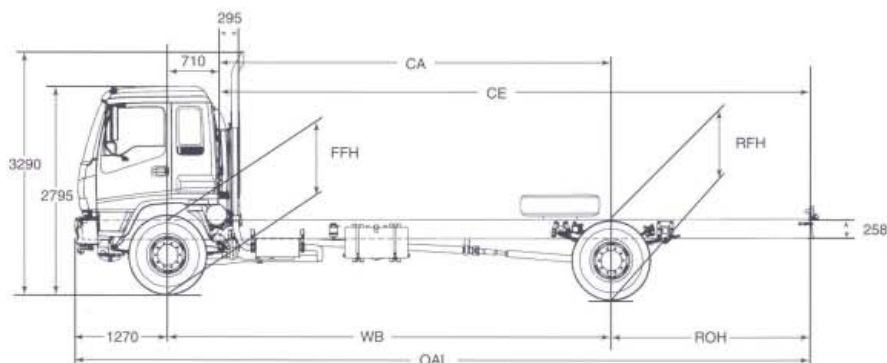
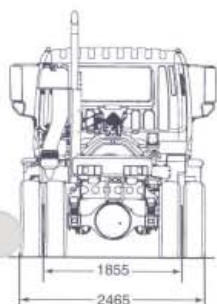

ISUZU GENERAL MOTORS AUSTRALIA LTD A/CN. (906 905 582) (1 800 900 WARRANTY). Subject to the conditions of the Isuzu New Vehicle Warranty, every Isuzu Truck carries a warranty which covers (as set out in the Isuzu 3 Year/100,000km or 5 Year/150,000km whichever comes first) against major engine, gearbox, transmission and chassis components with the new Isuzu 3 Year/100,000km or 5 Year/150,000km limited mileage cab corrosion warranty. PLEASE NOTE: in the event of a claim, Isuzu will not be liable for consequential or special damages, and you will be liable to pay for any excess or co-insurance. All body, electrical and non-standard equipment. No Isuzu dealer or other person is authorised or permitted to give or make any statement, assurance or undertaking in relation to the quality, performance, characteristics, description or fitness for any purpose of any Isuzu product or its construction with the supply of any Isuzu product which is of various parts and systems, accessories or attachments, or any of those subjects, prior or made by Isuzu in its published sales literature, and the customer accepts no liability for any such unauthorised action. Isuzu has franchise dealers in many parts of Australia, for the sale of service parts and the provision of service to the owners of Isuzu products. Every endeavour is made to ensure that such dealers carry adequate stocks of service parts and are equipped to provide satisfactory service, but makes no promise, other than that contained in the Isuzu New Vehicle Warranty, that such parts or service facilities will be available or available at any particular location or at any particular time. A list of such franchise dealers is available through the Isuzu website www.isuzu.com.au and the right is reserved to make changes at any time without notice, in prices, colours, materials, equipment and models. Your Isuzu dealer has details and before ordering, you should ask him/her to bring you up to date.

ISUZU
RELIABILITY IS EVERYTHING

AIR CLEANER

- Donaldson 11" two stage with vertical air intake stack and rain head.

CHASSIS FRAME

- Parallel rail, ladder type channel section, cold riveted.
- Straight frame for easy body mounting. Frame width 850 mm.
- Side member dimensions 258 mm x 85 mm x 10 mm.
- Frame reinforcement angle section 224 mm x 75 mm x 4.5 mm.
- Material SAPH440 weldable mild steel.

COOLING SYSTEM

- 6 blade plastic cooling fan 500 mm diameter with thermatic fan clutch.
- Corrugated fin radiator with fan shroud. Frontal area 3820 cm². Coolant capacity 23.3 litres.

ELECTRICAL SYSTEM

- Batteries - 2 x 12 volt / 65 amp/h, negative earth.
- Alternator - 24 volt / 40 amp.
- Starter motor - 24 volt / 4.5 kW.
- Rear stop and tail lamps and licence plate lamp with long leads for variable body mounting.

EXHAUST SYSTEM

- Horizontal exhaust muffler with vertical exhaust stack.
- Exhaust brake, air controlled.

FRONT AXLE ISUZU F063 CAPACITY 6300 KG

- Reverse Elliot I-beam type. King pin diameter 50 mm with cylindrical roller thrust bearing.

FRONT SUSPENSION

- Semi-elliptical, alloy steel tapered multi-leaf springs. Fully wrapped eye with greaseable shackles.
- | Length | x | Width | x | Thickness | x | No. leaves |
|---------|---|-------|---|-----------|---|------------|
| 1470 mm | x | 80 mm | x | 11 mm | x | 2 |
| | | 80 mm | x | 12 mm | x | 2 |
| | | 80 mm | x | 13 mm | x | 5 |
- Hydraulic, double acting, telescopic shock absorbers.

FUEL SYSTEM

- In line plunger, Bosch 'ADS' type fuel injection pump with mechanical all speed governor. In line filter, see through water separator with drain cock. Single fuel tank, capacity 180 litres.

LUBRICATION SYSTEM

- Pressure feed lubrication with combination full flow and partial flow by-pass filter. Plate type oil cooler in water jacket. Oil capacity 13.5 litres including filter.

REAR SUSPENSION

- Semi-elliptical, alloy steel tapered multi-leaf springs. Fully wrapped eye with greaseable shackles.
- | Length | x | Width | x | Thickness | x | No. leaves |
|----------------|---|--------|---|-----------|---|------------|
| Main : 1420 mm | x | 100 mm | x | 12 mm | x | 8 |
| Aux : 980 mm | x | 100 mm | x | 10 mm | x | 2 |
| | | 100 mm | x | 11 mm | x | 4 |

STEERING

- Fully integral, power assisted, recirculating ball type.
- Gear ratio 22.4 : 1. Turns lock to lock 4.5.
- Gear driven vane type oil pump. Oil capacity 2.5 litres.

TOOLS

- Lockable tool box with 10000 kg capacity jack and wheel changing tools, tool kit.

WHEELS AND TYRES

- 8.25 x 22.5, 10 stud disc wheels, 11R22.5 tubeless tyres front and rear.
- Number of wheels and tyres 7, including spare.

CAB EXTERIOR

- All steel cab with welded strengthening ribs and side door impact beams. Torsion bar assisted manual tilt to 45°.
- 4 silicon filled rubber cab isolators.
- Cation electrodeposition primer.
- Bumper bar with step holes and footplate.
- Halogen headlamps, hinged for easy bulb replacement. Park lamps and cab clearance lamps.
- Turn signal lamps in front bumper and over wheel arches.
- 2 speed wiper/washer with variable intermittent mode. Triple washer jets mounted on wiper arms.
- Tinted, laminated windshield; tinted, toughened side and rear glass.
- West Coast type rear view mirrors. Convex mirror surface on passenger side.
- Alloy non-slip cab entry steps.
- Lift up front access panel for clutch and windscreen washer fluids, cab air filter screen. Engine fluid check points at rear of cab.

CAB INTERIOR

- Fully trimmed cab interior with cloth seat facings, formed roof lining. Overhead storage lockers. Driver and passenger sun visors.
- Centre storage compartment with lockable lid/tray.
- Pull out drinks holder in centre fascia, cigarette lighter with ash trays in doors.
- Driver's seat with mechanical suspension and 3 way lumbar support. Adjustment for seat back recline, seat slide and weight control.
- Outboard reclining passenger seat.
- Lap/sash seat belts with emergency locking retractors.
- Tilt/telescopic adjustable steering column, soft feel urethane steering wheel.
- Easy entry grab handles on 'A' and 'B' pillars.
- Heater demister with 4 speed fan, 4 outlet vents to screen, 5 fascia outlets, 5 foot outlets, demister ducts to door glass.
- AM/FM radio cassette with digital clock, dash mounted.
- DIN standard aperture in dash for CB radio.
- Park brake activation lever at left side of driver's seat.
- Rear vision mirror.
- Passenger side assist grip.
- Driver's left foot rest.
- Cab exhaust vents rear/upper cab.
- Business card clip. Coat hook at rear of cab.
- Elastic mesh pocket on driver's door.

INSTRUMENTATION

- Speedometer, odometer, trip meter and tachometer.
- Gauges for coolant temperature, fuel level and brake air pressure.

INDICATOR LAMPS

- Turn signals, parking brake on, high beam on, exhaust brake engaged.
- Reversing lamp and beeper.

WARNING LAMPS

- With warning bulb check switch.
- Battery charge, oil pressure, low air pressure, brake system, stop and tail light failure.

CONTROLS

- Left side combination stalk switch for exhaust brake, windscreen wipers and washer, hazard lamps.
- Right side combination stalk switch for headlamps, high beam and turn signals.
- Engine idle speed adjust control.
- Key operation for engine start and stop, external engine crank switch for service when cab is tilted.
- 3 way switch for interior lamp activated by driver and passenger doors.
- 24 volt-2 pin accessory plug in centre console.

FVR 900 LONG

ISUZU

RELIABILITY IS EVERYTHING