

ISUZU

NPS 250 4x4/ NPS 300 4x4



NPS 300 pictured



ISUZU
RELIABILITY IS EVERYTHING

AT A GLANCE

GVM	4,490 – 6,000 kg
GCM	7,990 – 9,500 kg
Engine Type	Isuzu SiTEC 150
Displacement	5.2 L
Power	110 kW @ 2,600 rpm
Torque	404 Nm @ 1,500 – 2,600 rpm
Wheelbase	3,400 mm

Driveline and Chassis Specification

Engine SiTEC 150 (ISUZU 4HK1-TCN)

Type: 4 cylinder 16 valve SOHC direct injection diesel.
Turbocharged and air-to-air intercooled.
Adjustable roller type rocker arms.

Displacement: 5,193 cc
Compression Ratio: 18.5:1
Bore x Stroke: 115 x 125 mm
Max power (80/1269/EEC-NET): 110 kW (148 HP) @ 2,600 RPM
Max torque (80/1269/EEC-NET): 404 Nm (298 lb.ft) @ 1,500 – 2,600 RPM
Emissions Standard: ADR 80/00 (Euro III)

Lubrication System

- Plate type cooler. 13 L capacity. Combined full flow main and bypass filter.

Cooling System

- 6 blade, 440 mm diameter cooling fan with thermostatically controlled viscous clutch. Dual drive belts and thermostats.
- Radiator frontal area: 3,227 cm²
- Coolant capacity: 14 L

Air Intake System

- Vertical air intake mounted on back of cab. 220 x 320 mm air cleaner element.
- 500 x 370 mm air-to-air intercooler.

Fuel System

- Denso common rail fuel injection. Combined fuel filter and water separator.
- 125 L steel tank.

Clutch

- Auto adjusting hydraulic control.
- Single plate 325 mm diameter.
- Total lining area: 966 cm²

Transmission

Isuzu MYY-5T

- 5 speed manual.
 - Synchromesh on gears 1-5
 - PTO provision on LHS of transmission case. PTO drive from counter gear.
 - Gear ratios (: 1)
- | 1st | 2nd | 3rd | 4th | 5th | Rev |
|-------|-------|-------|-------|-------|-------|
| 5.315 | 3.053 | 1.655 | 1.000 | 0.721 | 5.068 |

Transfer Gearbox

- High ratio: 1.00:1, Low ratio: 1.842:1
- Part time 4WD.

Axles

Front: Isuzu FDo26

- Full floating, Banjo type. Birfield outer joints and manual lock front hubs. 2,600 kg capacity.
- Drive ratio: 5.125:1

SiTEC 150
Maximum Power : 110 kW @ 2,600 RPM
Maximum Torque : 404 Nm @ 1,500-2,600 RPM

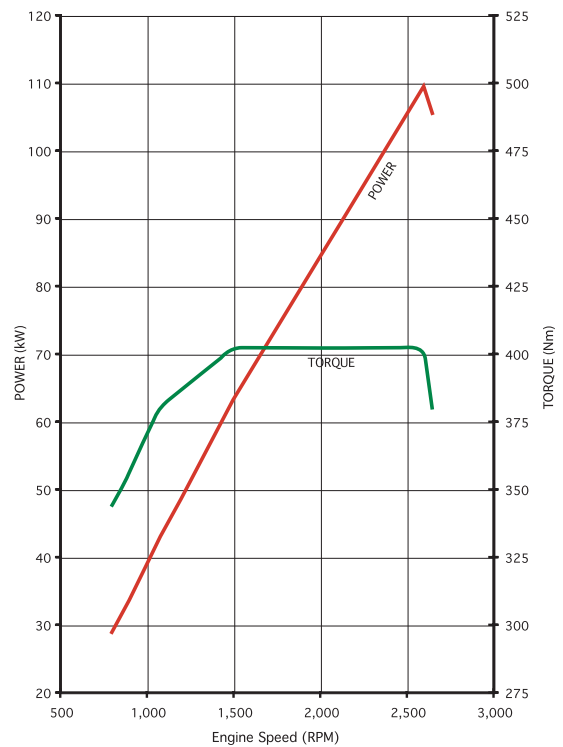

ISUZU SiTEC 150 (4HK1-TCN) ENGINE PERFORMANCE CHART

Rear: Isuzu Ro40

- Full floating Banjo type. Four pinion limited slip differential. 4,000 kg capacity.
- Drive ratio: 5.125:1

Suspension

Front

- Single stage alloy steel multi-leaf springs.
- Nominal size: 1,300 x 70 mm.
- Total spring capacity (at ground): 3,010 kg.
- Double acting hydraulic shock absorbers. Stabiliser bar.

Rear

- Multi-leaf main spring, multi-leaf helper spring.
- Nominal size: 1,300 x 70 mm.
- Total spring capacity (at ground): 4,510 kg.
- Double acting hydraulic shock absorbers.

Brakes

- Front and rear drum brakes with dual circuit hydraulic control, vacuum assistance and load sensing proportioning valve.
- Front drum diameter: 320 mm.
- Rear drum diameter: 320 mm.
- 190 mm diameter drum park brake mounted on rear of transmission.
- Vacuum controlled exhaust brake.

NPS 250 4x4
NPS 300 4x4

Wheels and Tyres

- 17.5 x 6.00 Six stud wheels.
- 8.5R 17.5TL 121/120L Michelin XZY Tubeless.
- Maximum tyre rating: 1,450 kg per tyre (single tyres),
1,400 kg per tyre (dual tyres).
- 1 frame mounted spare wheel and tyre assembly.

Axle Load Summary

	Front	Rear
Axle Capacity (kg):	2,600	4,000
Spring Capacity (kg):	3,010	4,510
Tyre Capacity (kg):	2,900	5,600
Limit (kg):	2,600	4,000

Note: Vehicle loading limit is determined by the combination of axle loading limit, GVM and GCM limit, and government regulatory requirements. Consult your Isuzu dealer to select the correct vehicle for your specific application.

Steering

- Power assisted recirculating ball steering.
- Gear ratio: 20.9:1
- Turns lock to lock: 3.7

Chassis Frame

- Cold riveted ladder frame. JIS-SAPH440 weldable steel.
- Frame dimensions
Side rail (mm): 203 x 65 x 6.0
Rear frame width (mm): 750

Electrical System

- 24 Volt electrical system.
- 24 Volt, 60 Amp alternator.
- 24 Volt, 4.5 kW starter motor.
- 2x 80D26R (582CCA) batteries connected in series.

Cabin Specifications and Appointments

Cab Exterior

- All steel cab with side door impact door protection beams. Outer body panels galvanised and treated with corrosion resistant primer.
- Cab built to comply with ECE-R29 crash safety tests.
- Manual cab tilt to 45°.
- Access to fluid checkpoints without tilting cab.
- Four point tuned rubber cab mounting.
- Body coloured steel front bumper.
- Heavy duty non slip entry steps.
- 90° opening internally reinforced doors.
- Water spray suppression guards, and front mudflaps.
- Laminated windscreen.
- Two speed windscreen wipers, with intermittent wipe mode.
- Single piece halogen multi-reflector headlamps incorporating turn signals.
- Combination brake, turn, reverse and marker lamps, registration plate illumination lamps. Extended wiring harness. Reverse alarm.
- Roof-mounted clearance lamps.
- "West Coast" type rear view mirrors. Large flat mirror glass with additional, independently adjustable convex "spot" mirror on both sides.

Cab Interior

- Wide contoured driver's bucket seat, lumbar support, reclining back, fore-aft adjustment. Two person passenger bench seat, with folding seat back. Seat tilts for access to engine. Durable, fire resistant cloth seat facing.
- 3-point, lap sash seatbelts with emergency locking belt retractors in all outboard seating positions.
- Door and "A" pillar entry assist grips.
- Full interior trim, padded roof lining, and vinyl floor mats. Windscreen header storage shelf.

- Tilt/Telescopic adjustable steering column, soft feel urethane steering wheel.
- Electric windows.
- Central locking with remote keyless entry.
- Twin cup holders. Cigarette lighter.
- Centre console box with two storage trays. Fold down storage tray behind centre seat backrest.
- Standard fully integrated air conditioning and heater/demister with 4-speed fan and outlets for windscreen, side windows, face and floor.
- Fore-aft adjustable roof vent.
- Interior lamp with On/Door/Off switch activated by either door.
- Two speaker Eurovox Radio/CD player with digital anti skip memory.
- Optional 10 stack CD player.
- DIN sized compartment below radio for storage or for CB radio installation.

Driver Controls

- Key-operated engine start/stop and steering lock. Engine idle speed control.
- **Left side combination stalk:** Windscreen wipers, washers and exhaust brake.
- **Right side combination stalk:** Turn signals and headlamps.
- Separate stalk for 4WD High/Low selection.

Instrumentation

- **Gauges:** Electronically driven speedometer and tachometer. Digital odometer with integrated dual tripmeter. Engine coolant temperature and fuel level gauges.
- **Warning lamps:** Low battery charge, brake failure, low fuel level, glow plug/engine malfunction, low oil pressure, water separator.
- **Indicator lamps:** Turn signals, parking brake, high beam, exhaust brake engaged, 4WD engaged.

Performance (Calculated)

	NPS 250 4x4	NPS 300 4x4
Max Geared speed:	106 km/h @ 2,650 rpm	106 km/h @ 2,650 rpm
Gradeability (lowest gear):	100% at 4,490 kg GVM	76% at 6,000 kg GVM
Gradeability (top gear at 100 km/h):	2.7% (2.3 m wide tray body at 4,490 kg GVM)	1.9% (2.3 m wide tray body at 6,000 kg GVM)
Engine speed (top gear at 100 km/h):	2,505 rpm	2,505 rpm

Performance figures quoted are representative only and based on typical dimensions, body styles and weights. Please consult your Isuzu dealer for an estimation based on your specific application.

Ratings, Dimensions and Order Codes

Models	Ratings (kg)		Tare Mass* (kg)			Dimensions (mm)													Turn Circle KERB to KERB
	GVM	GCM	TOTAL	FRONT	REAR	WB	OAL	FOH	ROH	EA	CE	RT	ORT	CH	CW	FFH UNLADEN	RFH UNLADEN		
250 4x4	4,490	7,990	2,725	1,810	915	3,400	5,955	1,060	1,495	2,720*	4,370	1,525	1,990	2,460	1,995	940	820	14.0 m	
300 4x4	6,000	9,500	2,725	1,810	915	3,400	5,955	1,060	1,495	2,665	4,370	1,525	1,990	2,460	1,995	940	820	14.0 m	

TOWING CAPACITY • Unbraked trailer: 750 kg • Braked trailer: 3,500 kg

*with horizontal exhaust

Estimated mass of cab/chassis with oil, water and fuel tank containing 10 litres of fuel and including spare wheel and tools.

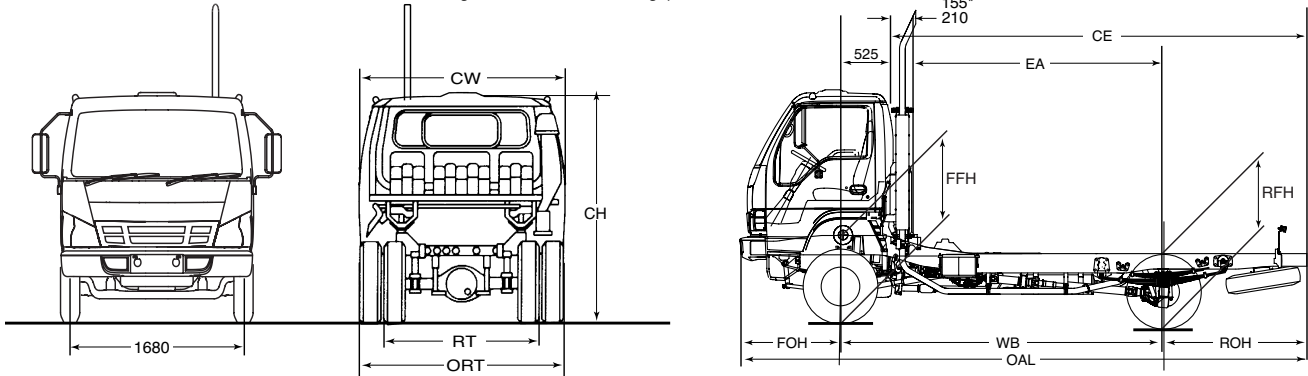

For further information regarding Cab/Chassis dimensions your Isuzu Dealer can access detailed Body Builders diagrams from the Isuzu Truck Technical Reference CD.

	Model	Standard
Order Codes	NPS 250 4x4	8NW02-SBM (C7A)
	NPS 300 4x4	8NW02-SBM

ISUZU New Truck Warranties

Standard Truckpower Warranty*			Truckpower Extended Warranty Options#		
New Vehicle	3 years	100,000 km	4 years 200,000 km	5 years 250,000 km	6 years 300,000 km
Drivetrain	3 years	100,000 km			
Cab Corrosion	3 years	unlimited			

* Subject to the conditions outlined in the I-GM New Vehicle Warranty, the Isuzu NPS models carry a standard factory warranty which covers the owner: (i) for the entire vehicle, for the first 36 months or 100,000 km (whichever comes first). (ii) for the drivetrain, which runs concurrently, for 36 months or 100,000 km (whichever comes first). (iii) against cab corrosion, for 36 months and unlimited kilometres.

A TruckPower Extended Warranty as illustrated is available by purchase to cover the owner against the failure of original components, but excludes some components and expendable items such as oil, filters, etc. Please consult with your Isuzu Dealer for full details obtained from a dedicated brochure available to customers.

ISUZU-GENERAL MOTORS AUSTRALIA LTD A.C.N. 006 962 572. PLEASE NOTE: as the policy of I-GM is one of continual product improvement, all specifications and equipment are subject to change without notice. No I-GM dealer or other person is authorised or permitted to give or make any statement, assertion or undertaking in relation to the quality, performance, characteristics, descriptions or fitness for any purpose of any I-GM product or in connection with the supply of any I-GM product which is at variance with any written statement, assertion or undertaking on any of these subjects given or made by I-GM in its published sales literature, and the company accepts no liability for any such unauthorised action. I-GM has franchised dealers in many parts of Australia, for the sale of service, parts and the provision of service to the owners of I-GM products. Every endeavour is made to ensure that such dealers carry adequate stocks of service parts and are equipped to provide satisfactory service, but makes no promise, other than that contained in the I-GM new vehicle warranty, that such parts or service facilities will be available or available at any specific location or at any particular time. A word about this specification sheet. We have tried to make it as comprehensive and factual as possible. However, since the time of printing some of the information you will find here may have been updated. Also, some of the equipment shown or described through this specification sheet may have been changed and/or is available at extra cost. And the right is reserved to make changes at any time without notice, in prices, colours, materials, equipment and models. Your I-GM dealer has details and before ordering, you should ask him/her to bring you up to date.

October 2005. ARK/IGM 0176

NPS 250 4x4
NPS 300 4x4

ISUZU
RELIABILITY IS EVERYTHING