

# ISUZU

SPECIFICATIONS

**NEW**  
NEW GENERATION ISUZU  
**GEN**

## GVD



AUSTRALIA'S TOP SELLING TRUCK BRAND SINCE 1989. Truck tracker 2007.

### AT A GLANCE

<b>GVM</b>	16,500 kg
<b>GCM</b>	36,000 kg
<b>Power</b>	221 kW @ 2,400 rpm
<b>Torque</b>	981 Nm @ 1,450 rpm

### ADVANCED TECHNOLOGY

- Driver airbag with seatbelt pretensioner
- ADR 42 compliant sleeper with mattress
- Anti-lock Braking System (ABS)
- Hill Start Aid (HSA)
- Electric mirrors
- Electro-hydraulic cab tilt
- Coil spring cab suspension
- Front stabiliser bar
- Cruise control
- ISRI 6860 seat with integrated seatbelt

RELIABILITY IS EVERYTHING **ISUZU**

## Driveline & Chassis Specifications

### ENGINE: SITEC SERIES II 295 (ISUZU 6HK1-TCS)

- Type:** 6 cylinder 24 valve SOHC  
**Displacement:** 7,790 cc  
**Compression Ratio:** 17.5:1  
**Bore x Stroke:** 115 x 125 mm  
**Max power (DIN-NET):** 221 kW (296 HP) @ 2,400 RPM  
**(JIS Gross):** 228 kW (306 HP) @ 2,400 RPM  
**Max torque (DIN-NET):** 981 Nm (724 lb.ft) @ 1,450 RPM  
**(JIS Gross):** 1,104 Nm (748 lb.ft) @ 1,450 RPM  
**Induction system:** Electronically controlled variable nozzle turbocharger with air-to-air intercooler.  
**Fuel injection:** Direct injection high pressure common rail system.  
**Emission control system:** Two-stage electronically cooled EGR with exhaust Diesel Particulate Diffuser (DPD). ADR 80/02 (Euro IV) compliant.

### CLUTCH

- Air assisted hydraulic control. Single plate 381 mm diameter.
- Total lining area: 1,363 cm<sup>2</sup>

### TRANSMISSION

#### Eaton FS-8209A BBE

- 9 speed with air assisted shift.
- Synchromesh on gears 1-8. Repeat 'H' shift pattern.
- Two PTO openings on LHS of transmission case.
- Gear ratios (: 1) Low: 12.64

1st	2nd	3rd	4th	5th	6th	7th	8th	Rev
8.81	6.55	4.77	3.55	2.48	1.85	1.34	1.00	13.17

### AXLES

#### Front: MERITOR

- FG941 reverse Elliot I-beam. 6,600 kg capacity.

#### Rear: MERITOR

- RS-23-161G, 10,400 kg capacity.
- Drive ratio: 4.56:1

### SUSPENSION

#### Front:

- Single stage alloy steel taper leaf springs.
- Double acting hydraulic shock absorbers. Stabiliser bar.

#### Rear:

- Hendrickson HAS230 airbag. 10,400 kg capacity at ground.
- Outboard mounted double acting shock absorbers.

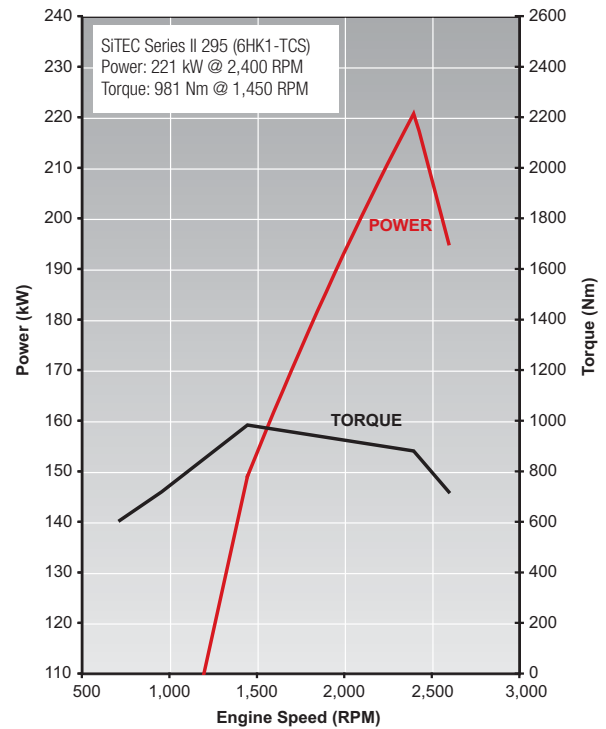

### BRAKES

- Meritor 'Q-Plus' dual circuit full air 'S-cam' front and rear drum brakes with auto slack adjusters and LSPV.
- ABS.
- Hill Start Aid (HSA).
- Front drum size: 419 x 127 mm
- Rear drum size: 419 x 178 mm
- Spring park brake.
- Air controlled exhaust brake.
- Air dryer.
- Trailer brake connection at rear of cab.

### STEERING

- Power assisted recirculating ball steering.
- Gear ratio: 22.4:1
- Turns lock to lock: 5.4
- Maximum angle: 45° (inside wheel) / 35° (outside wheel)

## WHEELS AND TYRES

- 22.5 x 8.25 ten stud ISO standard steel wheels.
- **Steer axle:** 295/80R22.5 152/148M Michelin XZE2 Tubeless
- **Drive axle:** 11R22.5 148/145L Michelin XDE2 Tubeless
- Maximum tyre rating:
  - Steer axle: 7,100 kg
  - Drive axle: 11,600 kg
- Spare wheel and XZE2 tyre assembly without carrier.

## CHASSIS FRAME

- Cold rivetted ladder frame with parallel side rails. HT540A high tensile weldable steel sidemembers.
- Frame dimensions:
  - Side rail (mm): 254 x 85 x 8.0
  - Rear frame width (mm): 850

## FUEL TANK

- Frame mounted 400L aluminium fuel tank.
- Lockable fuel cap.

## ELECTRICAL SYSTEM

- 24 volt electrical system.
- 60 amp alternator.
- 24 Volt, 4.5 kW starter motor.
- 2 x 80D26L (630 CCA) batteries connected in series.

## Cabin Specifications and Appointments

### CAB EXTERIOR

- All steel construction with electro-hydraulic cab tilt. High tensile steel used for cab underframe.
- Full floating cab with coil spring suspension and hydraulic shock absorbers.
- Heavy duty non slip entry steps.
- 90° opening internally reinforced front doors.
- Water spray suppression guards and front mudflaps.
- Laminated windscreen with shade band.
- Two speed windscreen wipers, with intermittent wipe mode.
- Halogen multi-reflector headlamps incorporating turn signals and front foglamps. Additional door mounted side indicator lamps.
- Combination brake, turn, reverse and marker lamps, registration plate illumination lamps. Reverse alarm.
- Roof-mounted clearance lamps.
- Heated and powered exterior main mirrors with flat glass and additional powered convex "spot" mirrors.
- Body coloured grille.
- Body coloured steel air dam bumper.
- Trailer air and electrical connectors at rear of cab.

### CAB INTERIOR

- Isri 6860 air suspension driver's seat with pneumatic lumbar support, height, rake and automatic weight adjustment.
- Front passenger adjustable bucket seat and front centre seat with folding seat back.
- 3-point lap sash seatbelts in all outboard seating positions. Driver seatbelt with pre-tensioner integrated with driver seat. Centre seat lap belts.
- ADR 42 compliant sleeper with mattress.
- Driver airbag.
- Door and roof pillar entry assist grips.
- Full interior trim, padded roof lining and vinyl floor covering. Driver and passenger windscreen header storage shelf.
- Tilt/Telescopic adjustable steering column, soft feel urethane steering wheel.
- Electric windows.
- Central locking with remote keyless entry and immobiliser.
- Twin cup holders. 24V cigarette lighter. Dashboard hook.
- Front door mounted storage pockets and driver's side ashtray.

- Centre console box with storage tray. Fold down storage tray behind centre seat backrest.
- Front passenger glovebox.
- Fully integrated auto control air conditioning and heater/demister with 4-speed fan and outlets for windscreen, side windows, face and floor.
- Fluorescent type interior lamp with On/Door/Off switch.
- 2 DIN, two speaker radio/CD multimedia unit and module for Bluetooth/iPod input/SD card reader.
- DIN sized compartment for storage or for CB radio installation.

### DRIVER CONTROLS

- Key-operated engine start/stop and steering lock. Engine idle speed control.
- HSA slow/fast engagement control and on/off switch.
- DPD regeneration.
- **Left side combination stalk:** Windscreen wipers, washers and exhaust brake.
- **Right side combination stalk:** Turn signals, headlamps, cruise control.
- Trailer brake control valve.

### INSTRUMENTATION

- Electronically driven speedometer and tachometer. Digital odometer with integrated dual tripmeter. Engine coolant temperature, fuel level and air pressure gauges.
- **Warning lamps:** Check engine, oil pressure, ABS, SRS airbag, alternator charge, service brakes, park brake, seat belt unfastened, low air pressure, low fuel level, cab lock.
- **Indicator lamps:** HSA, warm up system, high beam, DPD status, exhaust brake, turn signals, cruise control.
- Multi-information display. Shows service interval, instantaneous and average fuel consumption, DPD bar chart, hourmeter, voltmeter, time/day/date and includes 40-120 km/h adjustable vehicle speed warning.

### OPTIONS AND GENUINE ACCESSORIES

Include the following (extra cost, check with dealer for availability):

- Replacement module for Bluetooth/iPod input/SD card reader/satellite navigation (includes NAVTEQ mapping).
- Up to two reversing cameras.
- Cloth seat covers.
- Rear axle cross locks.

# ISUZU

## SPECIFICATIONS

### Weights (kg)

Models	Ratings*		Loading Limit* (at ground)		Cab Chassis Mass#		
	GVM	GCM	Front	Rear	Front	Rear	Total
GVD Prime Mover	16,500	36,000	6,600	10,400	3,230	1,780	5,010

\* Vehicle ratings and front/rear weight limits are subject to government regulatory requirements and weight distribution analysis. 16,500 kg is maximum optional GVM rating. Consult your Isuzu dealer to select the correct vehicle for your specific application.  
# Cab chassis only as supplied and including 10 litres of fuel.

### Dimensions (mm)

Models	WB	OAL	FOH	ROH	EA	CE	RT	ORT	CH	FFA (unladen)	RFA (unladen)	RFH (unladen)	Turn Circle (m)
													KERB TO KERB
GVD Prime Mover	3,750	6,155	1,440	965	3,050	4,090	1,840	2,445	2,860	1,000	1,010	1,010	13.1

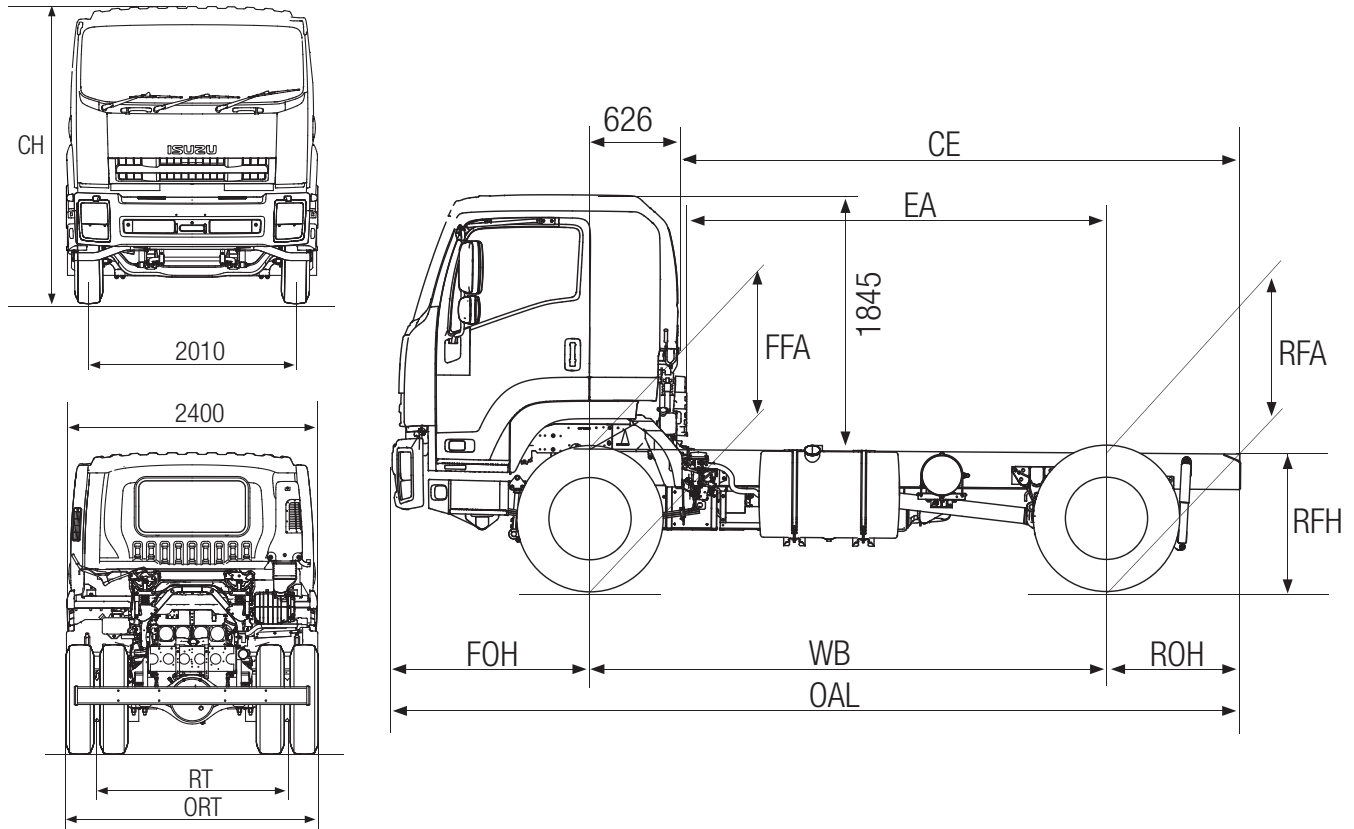

### Performance (calculated - typical paved road)

		Geared Speed* (top gear at peak power engine RPM)	Low Speed Gradeability (lowest forward gear assuming no wheel slip)	Engine Speed (top gear at 100 km/h)
GVD Prime Mover	At 36,000 kg GCM	102 km/h @ 2,400 RPM	27%	2,355 RPM

\* Maximum speed achievable depends on vehicle frontal area as well as other factors. Consult your Isuzu dealer for more detailed information. Vehicle is speed limited to 100km/h.

### Isuzu Warranties

STANDARD <sup>1</sup>		
New Vehicle	3 years   200,000 km   3,000 hrs	
Cab Perforation Corrosion	3 years   Unlimited km	
EXTENDED <sup>2</sup>		
4 years   300,000 km	5 years   350,000 km	6 years   400,000 km

<sup>1</sup> Subject to the conditions outlined in the IAL New Vehicle Warranty, the Isuzu GVD model carries a standard factory warranty which covers the owner: (i) for the entire vehicle, for the first 36 months or 200,000 km or 3,000 hrs (whichever comes first). (ii) against cab perforation corrosion, for 36 months and unlimited kilometres. <sup>2</sup> Extended Warranty as illustrated is available by purchase to cover the owner against the failure of original components, but may exclude some components and expendable items such as oil, filters, etc. Please consult with your Isuzu Dealer for full details obtained from a dedicated brochure available to customers.

ISUZU AUSTRALIA LIMITED ABN 97 006 962 572 ("IAL"). The information in this brochure was correct at time of printing, but all measurements, specifications and equipment are subject to change without notice. Some equipment may have been changed and/or is available at extra cost. IAL may make changes at any time without notice, in prices, colours, materials, equipment and models. IAL makes all reasonable attempts to ensure the availability of all vehicles and equipment. The information in this brochure is general in nature. Your Isuzu dealer can confirm all measurements, specifications and vehicle / equipment availability upon request.

July 2008. ARK0337

RELIABILITY IS EVERYTHING **ISUZU**