

ISUZU

SPECIFICATIONS

FSR 700 | 850 CNG



FSR 700 CNG

AUSTRALIA'S TOP SELLING TRUCK BRAND SINCE 1989.

AT A GLANCE

GVM	12,000 / 14,000 kg
GCM	18,000 / 20,000 kg
Power	162 kW @ 2,400 rpm
Torque	735 Nm @ 1,400 rpm

ADVANCED TECHNOLOGY

Emissions: JNLT 05 – meets ADR 80/03	Anti-lock Braking System (ABS)
Meets EEV emissions standard	Hill Start Aid (HSA)
Turbocharged multipoint injected CNG engine	Electric mirrors
Driver airbag with seatbelt pretensioner	Front stabiliser bar
ADR42 compliant sleeper	Isri 6860 seat with integrated seatbelt
	Cornering lamps



ISUZU

RELIABILITY IS EVERYTHING

DRIVELINE AND CHASSIS SPECIFICATIONS

ENGINE: CNG 220 (ISUZU 6HF1-TCN)

- Type:** 6 cylinder SOHC
- Displacement:** 7,790 cc
- Compression ratio:** 11.3:1
- Bore x Stroke:** 115 mm x 125 mm
- Max power (JIS D 1001 - NET):** 162 kW (217 HP) @ 2,400 RPM
- Max torque (JIS D 1001 - NET):** 735 Nm (542 lb.ft) @ 1,400 RPM
- Induction system:** Turbocharger with air-to-air intercooler.
- Ignition system:** Direct coil-over-spark plug ignition.
- Fuel injection:** Multipoint CNG injection.
- Emission control system:** Three-way exhaust catalyst. ADR 80/03 (J-NLT05) compliant. EEV compliant.

CLUTCH

- Air assisted hydraulic control. Single plate 381 mm diameter.
- Total lining area: 1,363 cm²

TRANSMISSION

Isuzu MZW-6P

- 6 speed manual with air assisted shift.
- Synchronesh on gears 2-6. Triple cone synchronesh on 2nd and 3rd gears. Integral oil pump provides full pressure lubrication.
- PTO provision on LHS of transmission case. PTO drive from mainshaft gear.

Gear ratios (:1)

1st	2nd	3rd	4th	5th	6th	Rev
6.615	4.095	2.358	1.531	1.000	0.722	6.615

AXLES

Front: Isuzu F050

- Reverse Elliot I-beam. 5,000 kg capacity.

Rear: Isuzu R090

- Full floating Banjo type. 9,000 kg capacity.
- Drive ratio: 4.875:1

SUSPENSION

Front:

- Single stage alloy steel taper leaf springs.
- Double acting hydraulic shock absorbers. Stabiliser bar.

Rear:

- Multi leaf main spring, multi leaf helper spring.

BRAKES

- Dual circuit air over hydraulic front and rear drum brakes.
- ABS.
- Hill Start Aid (HSA).
- Front drum size: 370 x 150 mm
- Rear drum size: 370 x 150 mm
- Spring park brake.
- Air controlled exhaust brake.
- Air dryer.

STEERING

- Power assisted recirculating ball steering.
- Gear ratio: 16.1 - 18.8:1
- Turns lock to lock: 4.1
- Maximum angle: 44° (inside wheel) / 34° (outside wheel)

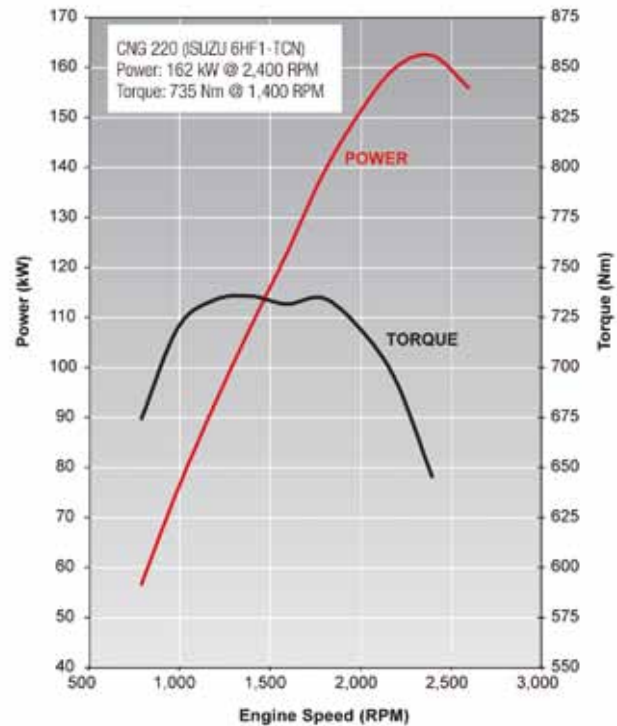

WHEELS AND TYRES

- 19.5 x 6.75 eight stud steel wheels.
- 265/70R19.5 140/138M Bridgestone V-Steel R294Z Tubeless.
- Maximum tyre rating:
 - Steer axle: 5,000 kg
 - Drive axle: 9,440 kg
- Spare wheel and tyre assembly with winch type carrier.

CHASSIS FRAME

- Cold rivetted ladder frame with parallel side rails. HT540A high tensile weldable steel sidemembers.
- Frame dimensions:
 - Side rail (mm): 225 x 70 x 6.0
 - Rear frame width (mm): 840

FUEL TANK

- 1 x carbon fiber wrapped aluminium CNG tank with 150L liquid capacity,
- 2 x steel type 2 CNG tanks with 100L liquid capacity each, 1 x steel type 1 CNG tank with 90L liquid capacity. Total capacity = 440 water litres.
- Operating pressure: 20 MPa / 3,000 psi approx.

ELECTRICAL SYSTEM

- 24 volt electrical system.
- 90 amp alternator.
- 24 volt, 4.5 kW starter motor.
- 2 x 115E41L (651 CCA) batteries connected in series.

CABIN SPECIFICATIONS AND APPOINTMENTS

CAB EXTERIOR

- All steel construction. High tensile steel used for cab underframe.
- Manual cab tilt to 45° with torsion bar assistance.
- Liquid filled front and rear cab mounts.
- Heavy duty non slip entry steps.
- 90° opening internally reinforced front doors.
- Water spray suppression guards and front mudflaps.
- Laminated windscreen with shade band.
- Two speed windscreen wipers with intermittent wipe mode.
- Halogen multi-reflector headlamps incorporating turn signals. Additional door mounted integrated side indicator/cornering lamps.
- Combination brake, turn, reverse and marker lamps, registration plate illumination lamps. Extended wiring harness. Reverse alarm.
- Roof-mounted clearance lamps.
- Heated and powered exterior main mirrors with flat glass and additional powered convex "spot" mirrors.
- Body coloured grille.
- Body coloured steel air dam bumper with front foglamps.

CAB INTERIOR

- Isri 6860 air suspension driver's seat with pneumatic lumbar support, height, rake and automatic weight adjustment.
- Front passenger adjustable bucket seat and front centre seat with folding seat back.
- 3-point lap sash seatbelts in all outboard seating positions. Driver seatbelt with pretensioner integrated with driver seat. Outboard front passenger seatbelt fitted with pretensioner. Centre seat lap belts.
- ADR42 compliant sleeper.
- Driver airbag.
- Door and roof pillar entry assist grips.
- Full interior trim, padded roof lining and vinyl floor covering. Driver and passenger windscreen header storage shelf.
- Tilt/Telescopic adjustable steering column, soft feel urethane steering wheel.
- Electric windows.
- Central locking with remote keyless entry.
- Twin cup holders. 24V cigarette lighter. Dashboard hook.
- Front door mounted storage pockets and driver's side ashtray.
- Centre console box with storage tray. Fold down storage tray behind centre seat backrest.
- Fully integrated air conditioning and heater/demister with 4-speed fan and outlets for windscreen, side windows, face and floor.
- Fluorescent type interior lamp with On/Door/Off switch.
- 2 DIN, two speaker radio/CD/DVD Digital Audio Visual Entertainment (DAVE) unit with 6.2" LCD touch screen. DAB+ digital radio and fully integrated Bluetooth with voice recognition. 4GB internal storage for music files. USB/SD card and auxiliary input connection provisions.
- DIN sized compartment for storage or for CB radio installation.

DRIVER CONTROLS

- Key-operated engine start/stop and steering lock.
- HSA slow/fast engagement control and on/off switch.
- **Left side combination stalk:** Windscreen wipers, washers and exhaust brake.
- **Right side combination stalk:** Turn signals and headlamps.

INSTRUMENTATION

- Electronically driven speedometer and tachometer. Digital odometer with integrated dual tripmeter. Engine coolant temperature, fuel level and air pressure gauges.
- **Warning lamps:** Check engine, oil pressure, ABS, SRS airbag, alternator charge, service brakes, park brake, seatbelt unfastened, low air pressure, low fuel level, cab lock.
- **Indicator lamps:** HSA, high beam, exhaust brake, turn signals.

OPTIONS AND GENUINE ACCESSORIES

Include the following (extra cost, request a brochure and further details from your Isuzu dealer):

Digital Audio Visual Entertainment unit:

- Isuzu satellite navigation including three years of free updates.
- Up to four reversing cameras - one with audio for reversing. Reversing sensors.
- Tyre pressure monitoring system.
- Cables for full iPod / iPhone / iPad compatibility and connection to other external audio visual devices.

Other:

- Airbag compatible bullbar.

ISUZU CARE

Isuzu Care gives truck owners access to products and services including Roadside Assist, Service Agreements, Extended Care, Extended Isuzu Assist and the Isuzu Care Centre. Call 1800 035 640.

WEIGHTS (kg)

Models	Ratings*		Loading Limit* (at ground)		Cab Chassis Mass #		
	GVM	GCM	Front	Rear	Front	Rear	Total
FSR 700 / 850 CNG	12,000 / 14,000	18,000 / 20,000	5,000	9,000	2,640	1,620	4,260

* Vehicle ratings and front/rear weight limits are subject to government regulatory requirements and weight distribution analysis. Consult your Isuzu dealer to select the correct vehicle for your specific application. # Cab chassis only as supplied with full fuel.

DIMENSIONS (mm)

Turn Circle (m)

Models	WB	OAL	FOH	ROH	EA	CE	RT	ORT	CH	FFA (unladen)	RFA (unladen)	RFH (unladen)	KERB TO KERB
FSR 700 / 850 CNG	4,660	7,875	1,170	2,045	4,030	6,150	1,705	2,245	2,600	770	885	925	16.7

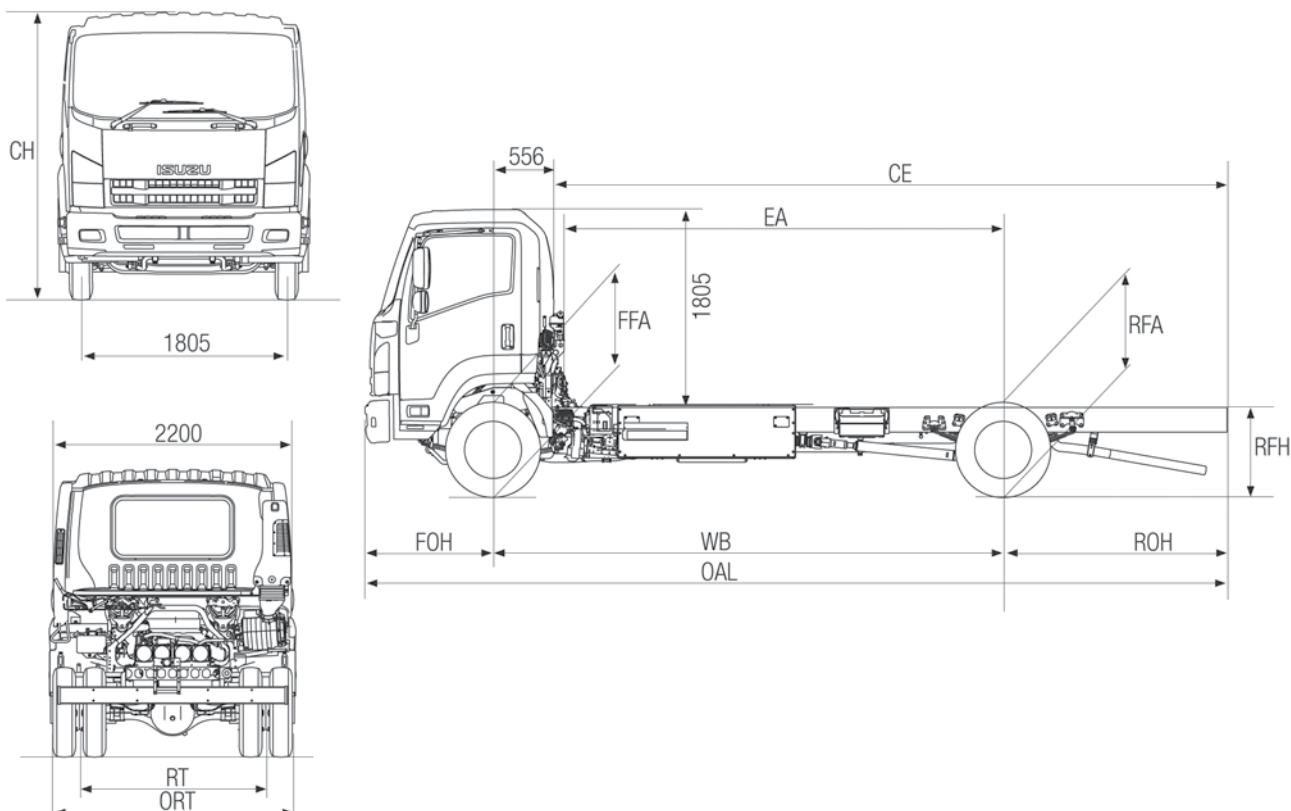

PERFORMANCE (calculated - typical paved road)

		Geared Speed* (top gear at peak power engine RPM)	Low Speed Gradeability (lowest forward gear assuming no wheel slip)	Engine Speed (top gear at 100km/h)
FSR 700 CNG	At 12,000 kg GVM	108 km/h @ 2,400 RPM	43%	2,215 RPM
FSR 850 CNG	At 14,000 kg GVM	108 km/h @ 2,400 RPM	36%	2,215 RPM

*Maximum speed achievable depends on vehicle frontal area as well as other factors. Consult your Isuzu dealer for more detailed information. FSR 850 CNG models speed limited to 100km/h.

ISUZU WARRANTIES

STANDARD¹

New Vehicle 3 years • 100,000km • 2,000 hours

Cab Perforation Corrosion 3 years • unlimited km's

Isuzu Assist: 24 hour roadside assistance (3 years, unlimited km's)*

EXTENDED CARE²

Extended Warranty: 5 years • 250,000 km • 5,000 hours

Isuzu Assist: 24 hour roadside assistance (5 years, unlimited km's)

ORDER CODES

Model	Code
FSR 700 CNG	FH-FSRCM-B13
FSR 850 CNG	FH-FSRCN-B13

1 Subject to the conditions outlined in the IAL New Vehicle Warranty, the Isuzu FSR models carry a standard factory warranty which covers the owner: (i) for the entire vehicle, for the first 36 months or 150,000 km or 2,500 hrs (whichever comes first). (ii) against cab perforation corrosion, for 36 months and unlimited kilometres. 2 Extended Warranty as illustrated may be purchased to cover the owner against the failure of original components, but may exclude some components and expendable items such as oil, filters, etc. *Valid for three years from the date of new vehicle purchases. All Isuzu warranties are subject to mandatory prescribed terms under Australian Consumer law including customer guarantees. For more details visit the Isuzu website which explains Isuzu warranties in more detail, or alternatively contact your local dealer. All warranties commence from date of delivery.

ISUZU AUSTRALIA LIMITED ABN 97 006 962 572 ("IAL"). The information in this spec sheet was correct at time of printing, but all measurements, specifications and equipment are subject to change without notice. Some equipment may have been changed and/or is available at extra cost. IAL may make changes at any time without notice, in prices, colours, materials, equipment and models. IAL makes all reasonable attempts to ensure the availability of all vehicles and equipment. The information in this spec sheet is general in nature. Your Isuzu dealer can confirm all measurements, specifications and vehicle / equipment availability upon request. To the extent permitted by the law, IAL is not liable to any person as result of reliance on the content of this spec sheet.

December 2012. ARK0614



ISUZU
RELIABILITY IS EVERYTHING