

200

NPR 200 AUTO

**GVM 4,490kg
GCM 4,490kg*
WHEELBASE 3365mm**

ISUZU 4HF1 ENGINE PERFORMANCE

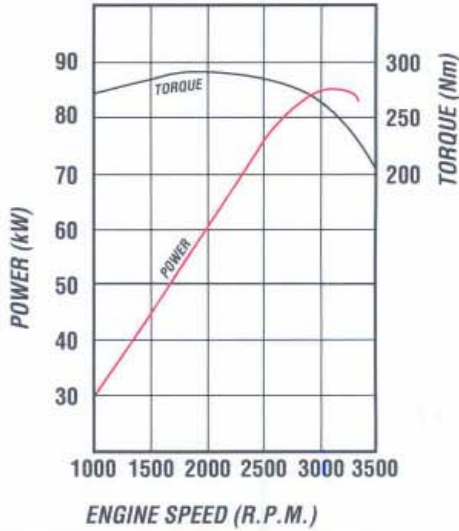

- Type: 4 cylinder, overhead camshaft diesel, four stroke, direct injection
- Bore x Stroke 112 x 100 mm
- Displacement 4334 cc
- Compression Ratio 18.5:1
- Output-Power 85 kW @ 3200 rpm (DIN Nett)
- Torque 289 Nm @ 1900 rpm (DIN Nett)

DIMENSIONS AND WEIGHTS

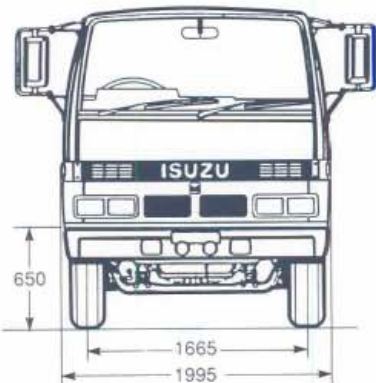
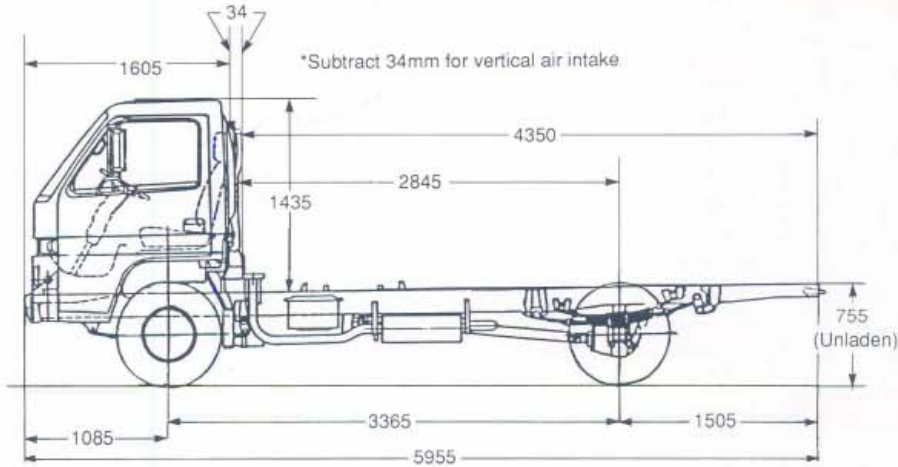

*ESTIMATED KERB MASS (kg)	
FRONT	1470
REAR	670
TOTAL	2140
FRAME WIDTH (mm) 750	
TURNING CIRCLE (m)	
Kerb to Kerb	13.0
BODY LENGTH (mm) 4570	
Subject to weight distribution	
RECOMMENDED MAX. BODY WIDTH (mm)	2286

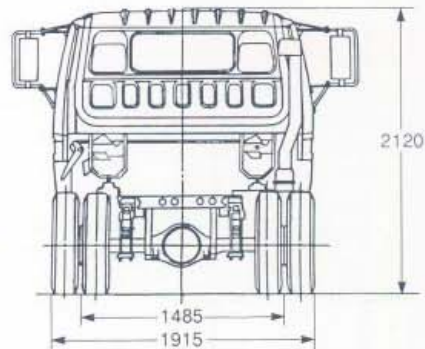

*Chassis and cab with oil, water and fuel tank containing 10 litres of fuel.
*Towing not recommended

ISUZU-GENERAL MOTORS AUSTRALIA LTD A.C.N. 006 962 572

12/20 WARRANTY. Every Isuzu Truck is covered by the I-GM new vehicle warranty which covers your vehicle for the first 12 months or 20,000 kilometres.

PLEASE NOTE: as the policy of Isuzu-General Motors Australia Motors is one of continual product improvement, all specifications and equipment are subject to change without notice. Body illustrated are not standard. No I-GM dealer or other person is authorised or permitted to give or make any statement, assertion or undertaking in relation to the quality performance characteristics descriptions or fitness for any purpose of any I-GM product or in connection with the supply of any I-GM product which is at variance with any written statement assertion or undertaking on any of these subjects given or made by Isuzu-General Motors Australia Limited in its published sales literature, and the company excepts no liability for any such unauthorised action. Isuzu-General Motors Australia Limited has franchised dealers in many parts of Australia. For the sale of service parts and the provision of service to owners of I-GM products. Every endeavour is made to ensure that such dealers carry adequate stocks of service parts, and are equipped to provide satisfactory service, but makes no promise, other than that contained in the New Vehicle Warranty given by Isuzu-General Motors Australia Limited, that such parts or service facilities will be available, or available at any specific location or any particular time.

ISUZU





200

NPR 200 AUTO

ORDERING CODE:
8NS02-222

ENGINE - ISUZU 4HF1

Lubrication:

- Pressure feed lubrication with full flow paper element and partial flow sub filter. Plate type oil cooler in water jacket.

Cooling System:

- Eight blade plastic cooling fan, size 430 mm diameter with thermatic fan clutch.
- Tube and corrugated fin pressure type radiator. Size (mm) 547 h x 471 w x 54 t. Frontal area 0.258 m².
- Automatic transmission cooler pipes in radiator lower tank.

FUEL SYSTEM

- Cartridge type paper element air cleaner, mounted high up on the chassis, with vertical air intake stack mounted behind cab.
- In line plunger, Bosch 'A' type fuel injection pump with mechanical all speed governor. In line paper filter. Fuel/water sedimentor with warning lamp.
- Fuel tank capacity 100 litres.
- Horizontal exhaust muffler and outlet pipe.

TRANSMISSION JATCO JR403E

- 4 speed automatic, floor shift, overdrive with torque converter lock up.
- **Gear ratios:1**

1st	3.068
2nd	1.570
3rd	1.000
4th	0.724
Reverse	2.625
- Maximum geared speed 98 km/h.
- Two piece propeller shaft, 82.6 mm diameter, length

1st section	838 mm
2nd section	970 mm

REAR AXLE - CAPACITY 5000 KG

- Banjo type, fully floating, single reduction. Ratio 5.857:1
- Hypoid type ring gear, 292 mm diameter. Oil capacity 3 litres

REAR SUSPENSION

- Semi elliptical, alloy steel, tapered multi leaf springs, with fully wrapped eye.
- Size: - length x width x thickness; no. leaves

Main:	1250 x 70 x 11 mm - 4 leaves
	850 x 70 x 10 mm - 1 leaf
Auxiliary:	850 x 70 x 9 mm - 4 leaves
	850 x 70 x 10 mm - 1 leaf
- Hydraulic, double acting, telescopic shock absorbers.

FRONT AXLE - CAPACITY 2700 KG

- Reverse Elliot I-beam type. King pin diameter 30 mm with cylindrical roller thrust bearing.

FRONT SUSPENSION

- Semi elliptical, alloy steel, tapered multi-leaf springs, with fully wrapped eye.
- Size: - length x width x thickness; no. leaves
1140 x 70 x 9 mm - 7 leaves
- Hydraulic, double acting, telescopic shock absorbers.

STEERING

- Fully integral power assisted recirculating ball type. Gear ratio 21.9:1. Turns lock to lock 5.0.
- Gear driven vane type oil pump, oil capacity 1.6 litres.

BRAKES

- Hydraulic dual circuit, vacuum assisted, ventilated front disc, 238mm diameter; rear drum dual two leading. Drum diameter 300 *x75* mm. Total swept area 2305 cm².
- Asbestos free lining material. Width 75mm.
- Mechanical park brake, internal expanding at rear of transmission. *Exhaust brake*

CHASSIS FRAME

- Ladder type, channel section, cold rivetted.
- Side member dimensions 173 x 65 x 6 mm

WHEELS AND TYRES

- 5.50F x R16 - 5 stud disc wheel, 16 mm bolt size.
- 7.00 R - 16 LT - 8 ply (Goodyear G22) tyres.
- Option: 700 - 16 LT - 8 ply (Olympic Trojan 56) tyres.
- Number of tyres, 7 including spare.
- Winch type spare wheel carrier.

ELECTRICAL SYSTEM

- Batteries - 2 x 12 volt - 50 amp/h, negative earth.
- Alternator - 24 volt - 35 amp.
- Starter motor - 24 volt - 3.5 kW output.
- Rear stop and tail lamps with long leads for variable body mounting.

CAB EXTERIOR

- All steel cab, manual tilt to 45°, aluminium non-slip entry steps.
- West Coast type rear view mirrors with clearance lamps.
- Access to fluid checks without tilting cab.
- Laminated windshield, 2 speed wiper/washer with intermittent mode.
- 4 rectangular sealed beam headlamps.
- Combination turn signal and park lamps.
- Front quarter vent windows.
- Tool kit with 5000 kg capacity jack.
- Engine access hatch in floor.

CAB INTERIOR

- Adjustable and reclining drivers bucket seat with lumbar support, 2 place passenger bench seat.
- Cloth seat material.
- Retractable lap/sash seat belts on outboard seats, lap belt on inboard seat.
- Driver and passenger sun visors, padded roof lining.
- Soft feel urethane steering wheel.
- Easy access pull down fuse cover.
- Easy entry grab handles on 'A' pillar.
- Windshield washer tank located in passenger door.
- Heater demister with 3 speed fan.
- AM/FM radio with digital clock, dash mounted.
- Optional air conditioning.

INSTRUMENTATION

- Speedometer with odometer and trip meter.
- Tachometer.
- Gauges for coolant temperature and fuel level.

INDICATOR LAMPS

- Turn signals, parking brake on, high beam on.

WARNING LAMPS

- Battery charge, oil pressure, brake failure, fuel level, coolant level, glow plug and water separator.

SWITCHES

- Left side combination switch for wipers and washer.
- Right side combination switch for turn signals and headlamps.
- Hazard switch.
- Key operation for engine stop start and steering wheel lock.
- Three way switch for interior lamp activated by driver and passenger doors.
- Fast engine warm-up control.