

FVR 900

GVM: *16000kg
GCM: 24000kg
WHEELBASE: 6000mm

*15,000 kg optional GVM.

900

ISUZU 6SA1 ENGINE PERFORMANCE

- Type: 6 cylinder, overhead camshaft diesel, four stroke, direct injection
- Bore x stroke: 115 x 135 mm
- Displacement: 8413 cc
- Compression Ratio: 16.5:1
- Output -
Power:
134kW @ 2520 rpm (DIN Nett)
Torque:
560 Nm @ 1400 rpm (DIN Nett)

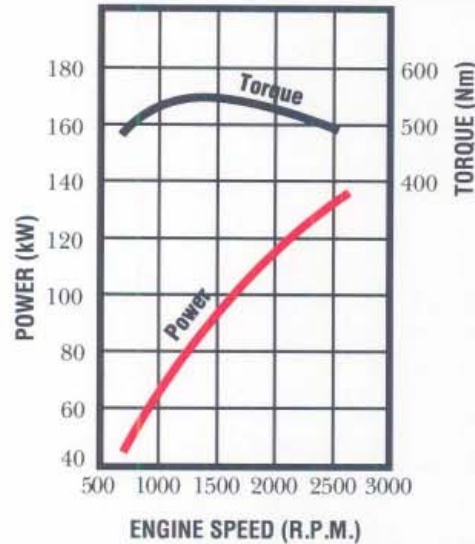

DIMENSIONS AND WEIGHTS

*ESTIMATED KERB MASS (kg)	
FRONT	2840
REAR	2280
TOTAL	5120
FRAME WIDTH (mm)	850
TURNING CIRCLE (m)	
Kerb to Kerb	24.9
BODY LENGTH (mm)	7320
Subject to weight distribution	
CHASSIS HEIGHT (mm)	
At centre line of rear axle	
UNLADEN CHASSIS CAB	1065
AT GVM	1004

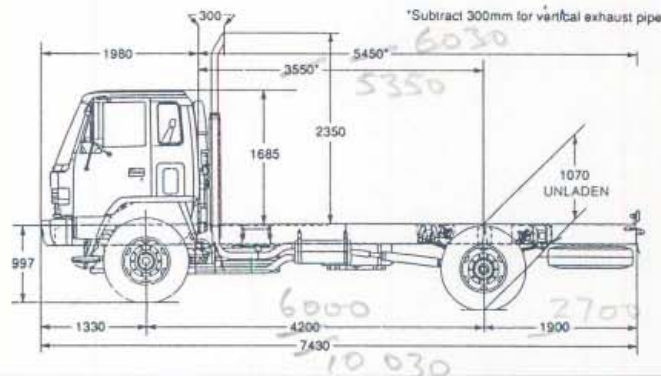
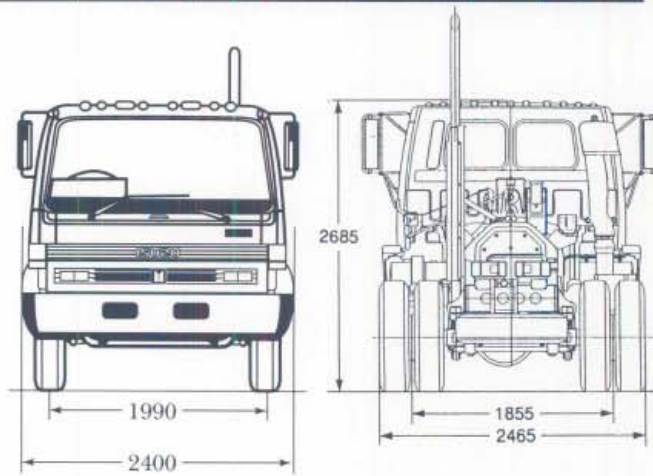

*Chassis and cab with oil, water and fuel tank containing 10 litres of fuel.

ISUZU-GENERAL MOTORS AUSTRALIA LTD A.C.N. 006 962 572.

12/50 WARRANTY: Every Isuzu Truck is covered by the I-GM new vehicle warranty which covers your vehicle for the first 12 months or 50,000 kilometres. PLEASE NOTE: as the policy of Isuzu-General Motors Australia Limited is one of continual product improvement, all specifications and equipment are subject to change without notice. Body illustrated is not standard. No I-GM dealer or other person is authorised or permitted to give or make any statement, assertion or undertaking in relation to the quality performance characteristics descriptions or fitness for any purpose of any I-GM product or in connection with the supply of any I-GM product which is at variance with any written statement, assertion or undertaking on any of these subjects given or made by Isuzu-General Motors Australia Limited in its published sales literature, and the company accepts no liability for any such unauthorised action. Isuzu-General Motors Australia Limited has franchised dealers in many parts of Australia, for the sale of service parts and the provision of service to owners of I-GM products. Every endeavour is made to ensure that such dealers carry adequate stocks of service parts, and are equipped to provide satisfactory service, but makes no promise, other than that contained in the New Vehicle Warranty given by Isuzu-General Motors Australia Limited, that such parts or service facilities will be available, or available at any specific location or any particular time.

ENGINE - ISUZU 6SA1

Lubrication

- Pressure feed lubrication with full flow paper element and partial fan sub filter. Plate type oil cooler in water jacket. Oil capacity 16.0 litres including filter.

COOLING SYSTEM

- 6 blade plastic cooling fan size 475 mm diameter with thermatic fan clutch.
- Tube and corrugated fin pressure type radiator with bell mouth fan shroud. Size (mm) 622 h x 559 w x 72 t. Frontal area 0.348 m².
- Coolant capacity 20.7 litres.

FUEL SYSTEM

- Two stage paper element air cleaner, Donaldson 11" with vertical air intake stack and rain head.
- In line plunger, Bosch 'AD' type fuel injection pump with mechanical all speed governor.
- In line paper filter, see through water separator with drain cock.
- Fuel tank capacity 180 litres.
- Horizontal exhaust muffler with vertical exhaust stack.

CLUTCH

- Hydraulic control dry single plate with coil type cushioning springs. 380 mm (15") diameter.
- Air servo assistance.
- Asbestos free lining material. Total lining area (both sides) 1362 cm².

TRANSMISSION ISUZU MLD7R

- 7 speed overdrive, constant mesh with synchromesh on gears 2-7 and power assisted shift control. Oil capacity 8.3 litres.
- Gear ratios: 1

1st	8.181
2nd	5.167
3rd	3.333
4th	2.105
5th	1.347
6th	1.000
7th	0.863
Reverse	8.307
- Maximum geared speed 99.8 km/h.
- Three piece propeller shaft, 101.6 mm diameter.

Length: 1st section	1104 mm
2nd section	1409 mm
3rd section	1190 mm.

REAR AXLE - (E)26070S CAPACITY 10,500 KG

- Banjo type, fully floating, single reduction. Ratio 5.571:1.
- Hypoid type ring gear, 431 mm diameter. Oil capacity 18.9 litres.

REAR SUSPENSION

- Semi-elliptical, alloy steel tapered multi-leaf springs. Fully wrapped eye with slipper brackets.
- Length - Width x thickness No. leaves

Main: 1420 - 100 x 12 mm	8 leaves
Aux: 980 - 100 x 10 mm	2 leaves
100 x 11mm	4 leaves

FRONT AXLE - F063 CAPACITY 6,300 KG

- Reverse Elliot I-beam type. King pin diameter 50 mm with cylindrical roller thrust bearing. Oil filled front hubs with demountable brake drums.

FRONT SUSPENSION

- Semi-elliptical, alloy steel tapered multi-leaf springs. Fully wrapped eye with greasable shackles.
- Length Width x thickness No. leaves

1470	80 x 12 mm	2 leaves
	80 x 14 mm	5 leaves
- Hydraulic, double acting, telescopic shock absorbers.

STEERING

- Fully integral power assisted recirculating ball type. Gear ratio 22.4:1. Turns lock to lock 5.4.
- Gear driven vane type oil pump, oil capacity 3.5 litres.

BRAKES

- Full air 'S' cam, dual circuit front and rear leading and trailing. Drum diameter 419 mm. Total swept area 8657 cm².
- Air tank capacity 50 litres with air dryer.
- Compressor bore x stroke 85 x 60 mm driven at half engine speed.
- Spring park brake acting on rear wheels.
- Butterfly, air controlled exhaust brake. Activation switch on wiper/washer control stalk.

CHASSIS FRAME

- Parallel rail, ladder type, channel section, cold rivetted.
- Side member dimensions 254 x 85 x 8 mm.
- Frame reinforcement angle section 224 x 77 x 4.5 mm at back of cab.
- Material, SAPH45 mild steel.

WHEELS AND TYRES

- 8.25 T x 22.5 - 10 stud disc wheels, 22 mm bolt size. 160 mm offset.
- 11R 22.5 - 16 ply radial tubeless tyres front and rear.
- Number of tyres, 7 including spare.

ELECTRICAL SYSTEM

- Batteries - 2 x 12 volt - 55 amp/h, negative earth.
- Alternator - 24 volt - 40 amp.
- Starter motor - 24 volt - 5.5 kW output.
- Rear stop and tail lamps and licence plate lamp with long leads for variable body mounting. Turn signal side indicator lamps for body mounting.

CAB EXTERIOR

- All steel cab, manual tilt to 45°. Torsion bar counter balanced.
- Cation, electro deposition primer.
- Heavy duty bumper bar.
- Four rectangular halogen headlamps.
- Combination turn signals and park lamps.

- Tinted laminated windshield, 2 speed wiper/washer with intermittent mode.
- Tinted quarter vent, side and rear glass.
- West Coast type rear view mirrors with clearance lamps.
- Corrosion resistant non slip cab entry steps.
- Access to engine fluid checks without tilting cab.
- Tool kit with 10,000 kg capacity jack.

CAB INTERIOR

- Air suspension drivers seat, reclining with seat slide and height control.
- Outboard passenger seat, fixed centre seat.
- Vinyl seat material, padded roof lining and heavy duty vinyl floor mat.
- Outboard lap/sash seat belts with emergency locking retractors, inboard lap seat belts.
- Tilt telescopic adjustable steering column, soft feel urethane steering wheel. Easy entry grab handles on 'A' and 'B' pillars.
- Heater demister with 4 speed fan, 4 outlet vents to screen, 5 fascia outlets, 5 foot outlets.
- AM/FM radio with digital clock, dash mounted.
- Park brake activation lever beside drivers seat.

INSTRUMENTATION

- Speedometer, odometer and tachometer.
- Gauges for coolant temperature, fuel level and brake air pressure.
- Dash illumination control.

INDICATOR LAMPS

- Turn signals, parking brake on, high beam on, exhaust brake engaged, brake fluid level.

WARNING LAMPS

- With warning bulb check switch.
- Battery charge, oil filter clogged, oil pressure, low air pressure, brake system, air cleaner clogged, stop and tail lamp failure.
- Reversing lamp.

SWITCHES

- Left side combination switch for exhaust brake, wipers and washer.
- Right side combination switch for headlamps, turn signals and headlamp dip.
- Hazard lamp switch.
- Key operation for engine stop and start, external engine crank switch for service when cab is tilted.
- Three way switch for interior lamp activated by driver and passenger doors.
- 24 volt 2 pin accessory plug on centre fascia panel.