

ISUZU

SPECIFICATIONS

GIGA EXY 240-460 6X4

Now with
Sat Nav fitted
as standard*



* Satellite Navigation functions and maps provided at no extra cost, with up to four quarterly updates provided by user free download for the first three years of ownership, after which updates can be purchased at additional cost.

AUSTRALIA'S TOP SELLING TRUCK BRAND SINCE 1989.

AT A GLANCE

GVM	24,000 kg
GCM	50,000 kg
Power	338 kW @ 1,800 rpm
Torque	2,255 Nm @ 1,300 rpm

ADVANCED TECHNOLOGY

Emissions: JNLT 05 - meets ADR 80/03	ECE-R29 compliant cab
Driver airbag with seatbelt pretensioner	ECE-R93 compliant front underrun protection device (FUPD)
Anti-lock Braking System (ABS)	ISRI 6860 seat with integrated seatbelt
Cross and inter-axle locks	



We
share
the
load.

ISUZU
RELIABILITY IS EVERYTHING

GIGA EXY 240-460 6X4

DRIVELINE AND CHASSIS SPECIFICATIONS

ENGINE: ISUZU 6WG1-TCC

Type: 6 cylinder 24 valve SOHC
Displacement: 15,681 cc
Compression Ratio: 16.5:1
Bore x Stroke: 147 mm x 154 mm
Max power (DIN - NET): 338 kW (453 HP) @ 1,800 RPM
(JIS Gross): 350 kW (469 HP) @ 1,800 RPM
Max torque (DIN-NET): 2,255 Nm (1,663 lb.ft) @ 1,300 RPM
(JIS Gross): 2,334 Nm (1,721 lb.ft) @ 1,300 RPM
Induction system: High capacity turbocharger with air-to-air intercooler.
Fuel injection: Direct injection high pressure common rail system.
Emission control system: Four-stage electronically controlled cooled EGR with exhaust Diesel Particulate Diffuser (DPD). ADR 80/03 (J-NLT05) compliant.

CLUTCH

Standard model:

- Spicer twin plate 15.5".
- Air assisted with clutch brake.

TRANSMISSION

Eaton RTLO 18918B

- 18 speed constant mesh.
- Integral oil pump and oil cooler.
- Gear ratios (:1)

LL	LH	1st L	1st H	2nd L	2nd H
14.4	12.29	8.56	7.30	6.05	5.16
3rd L	3rd H	4th L	4th H	5th L	5th H
4.38	3.74	3.20	2.73	2.29	1.95
6th L	6th H	7th L	7th H	8th L	8th H
1.62	1.38	1.17	1.00	0.86	0.73
RLL	RLH	RHL	RHH		
15.06	12.85	4.03	3.43		

AXLES

Front: MERITOR

- FG941 reverse Elliot I-beam. 6,600 kg capacity.

Rear: MERITOR

- RT-40-145GP tandem axle set. 18,100 kg capacity.
- Integral oil pump.
- Driver controlled inter-axle lock and cross locks on both axles.
- Drive ratio: 3.73:1

SUSPENSION

Front:

- Single stage alloy steel taper leaf springs.
- Double acting hydraulic shock absorbers. Stabiliser bar.

Rear:

- Hendrickson HAS461 airbag. 20,865 kg capacity at ground.
- Outboard mounted double acting shock absorbers.

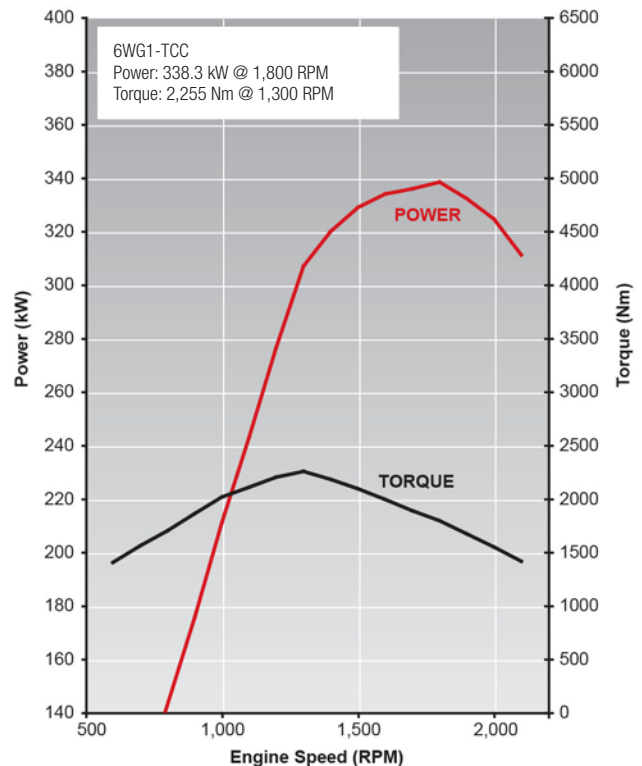

BRAKES

- Meritor 'Q-Plus' dual circuit full air 'S-cam' front and rear drum brakes with auto slack adjusters.
- ABS.
- Front drum size: 419 x 152 mm
- Rear drum size: 419 x 178 mm
- Spring park brake acting on all rear wheels.
- Air controlled exhaust brake.
- Air dryer.
- Trailer brake connection at rear of cab.

STEERING

- Power assisted recirculating ball steering.
- Gear ratio: 22.4:1
- Turns lock to lock: 4.4
- Maximum angle: 40° (inside wheel) / 32.2° (outside wheel)

WHEELS AND TYRES

- 22.5 x 8.25 ten stud ISO standard steel wheels.
- **Steer axle:** 295/80R22.5 152/148M Michelin X Line Energy Z Tubeless.
- **Drive axles:** 11R22.5 148/145L Michelin XJE4 Mix Energy Tubeless.
- Maximum tyre rating: Steer axle: 7,100 kg Tandem drive axle set: 23,200 kg
- Spare wheel rim supplied.

CHASSIS FRAME

- Cold rivetted ladder frame. HT540A high tensile weldable steel sidemembers.
- Frame dimensions:
 Side rail (mm): 285 x 85 x 8.0
 Rear frame width (mm): 850
- Turntable angles fitted.

FUEL TANK

- Frame mounted 550L aluminium fuel tank.
- Lockable fuel cap.

ELECTRICAL SYSTEM

- 24 volt electrical system.
- 90 amp alternator.
- 24 volt, 7.0 kW starter motor.
- 2 x 145G51 (754 CCA) batteries connected in series.
- 24 volt supply to trailer electrics.

CABIN SPECIFICATIONS AND APPOINTMENTS

CAB EXTERIOR

- All steel high roof cab with electro-hydraulic cab tilt.
- Complies with ECE-R29 cab strength standard.
- Full floating cab with air suspension and hydraulic shock absorbers.
- Heavy duty non slip entry steps.
- 90° opening internally reinforced front doors.
- Water spray suppression guards and front mudflaps.
- Laminated windscreen with shade band.
- Two speed windscreen wipers with variable intermittent wipe mode.
- Halogen headlamps. Bumper mounted turn signals and foglamps. Additional door mounted side indicator lamps.
- Combination brake, turn, reverse and marker lamps, registration plate illumination lamps. Reverse alarm.
- Roof-mounted clearance lamps.
- Heated and powered exterior main mirrors with flat glass and additional powered convex "spot" mirrors.
- Body coloured grille.
- FUPD underbar - complies with ECE R93.
- Body coloured steel air dam bumper.
- Trailer air and electrical connectors at rear of cab.

CAB INTERIOR

- Isri 6860 air suspension driver's seat with pneumatic lumbar support, height, rake and automatic weight adjustment.
- Front passenger adjustable bucket seat.
- 3-point lap sash seatbelts in all outboard seating positions. Driver seatbelt with pretensioner integrated with driver seat.
- ADR 42 compliant sleeper with mattress.
- Cab window curtain.
- Driver airbag.
- Door and roof pillar entry assist grips.
- Full interior trim, padded roof lining and carpet floor covering. Overhead front storage compartments.
- Tilt/Telescopic adjustable steering column, leather trimmed steering wheel.
- Electric windows.
- Central locking with remote keyless entry.
- 24V cigarette lighter. 12V electrical accessory sockets.
- Front door mounted storage pockets and ashtrays.
- Large centre console with storage compartments and heat/cool box.
- Fully integrated auto control air conditioning and heater/demister with 4-speed fan and outlets for windscreen, side windows, face and floor.
- Fluorescent type interior lamp with On/Door/Off switch.
- 2 DIN, two speaker radio/CD multimedia unit with 4.8" LCD touch screen and Bluetooth. Provision for SD card, USB and 3.5 mm plug inputs.

ISUZU SATELLITE NAVIGATION

- Integrated with radio/CD multimedia unit. Displayed information includes:
- Points of interest and Isuzu truck dealer locations
 - Road safety alerts
 - Speed limits and traffic signals
 - Route selection based on entered information such as vehicle weight and dimensions

DRIVER CONTROLS

- Key-operated engine start/stop and steering lock. Engine idle speed control.
- DPD regeneration.
- Inter-axle lock and cross lock engage switches.
- Rear suspension raise, lower and dump.
- Hi/lo horn control switch.
- **Left side combination stalk:** Windscreen wipers, washers, exhaust brake and hazard lamps.
- **Right side combination stalk:** Turn signals, headlamps, cruise control.
- Trailer brake control valve.

INSTRUMENTATION

- Electronically driven speedometer and tachometer. Digital odometer with integrated dual tripmeter. Engine coolant temperature, fuel level and air pressure gauges.
- **Warning lamps:** Check engine, oil pressure, ABS, SRS airbag, alternator charge, service brakes, park brake, trailer brake, seat belt unfastened, low air pressure, cab suspension, suspension height adjust.
- **Indicator lamps:** High beam, fog lamps, DPD status, exhaust brake, turn signals, cruise control.
- Multi information display. Shows instantaneous, average and idling fuel consumption, time/day/date, voltmeter, and vehicle systems status.

GENUINE ACCESSORIES

Include the following (extra cost, request a brochure and further details from your Isuzu dealer):

- Up to three audio/visual reversing cameras - integrates with multimedia unit.
- Airbag compatible bullbar.
- Additional fuel tank.
- Air deflector.

ISUZU CARE

Isuzu Care gives truck owners access to products and services including Roadside Assist, Service Agreements, Extended Care, Extended Isuzu Assist and the Isuzu Care Centre. Call 1800 035 640.

We
share
the
load.

ISUZU
RELIABILITY IS EVERYTHING

WEIGHTS (kg)

Models	Ratings*		Loading Limit* (at ground)		Cab Chassis Weight #		
	GVM	GCM	Front	Rear	Front	Rear	Total
EXY 240-460 PM	24,000	50,000	6,600	20,865	4,595	3,215	7,810

* Vehicle ratings and front/rear weight limits are subject to government regulatory requirements and weight distribution analysis. Consult your Isuzu dealer to select the correct vehicle for your specific application. # Cab chassis only as supplied and including 10 litres of fuel.

DIMENSIONS (mm)

Models	WB	OAL	FOH	ROH	EA	CE	RT	ORT	CH	FFA (unladen)	RFA (unladen)	RFH (unladen)	Turning Circle (m)
													KERB TO KERB
EXY 240-460 PM	3,885	6,930	1,400	1,645	2,450	4,766	1,850	2,440	3,200	915	1,035	1,040	14.6

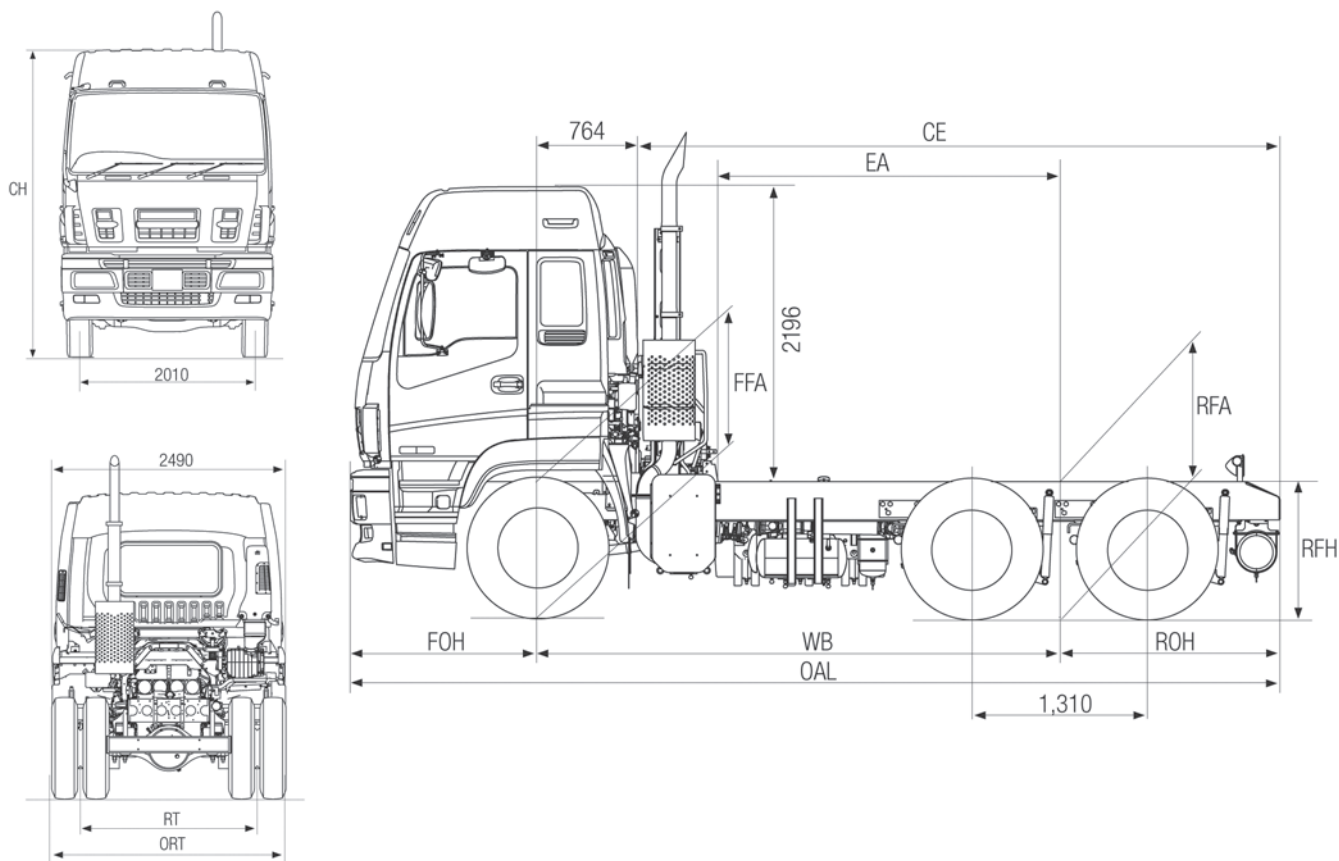

PERFORMANCE (calculated - typical paved road)

		Geared Speed* (top gear at peak power engine RPM)	Low Speed Gradeability (lowest forward gear assuming no wheel slip)	Engine Speed (top gear at 100km/h)
EXY 240-460	At 50,000 kg GCM	128 km/h @ 1,800 RPM	43%	1,405 RPM

* Maximum speed achievable depends on vehicle frontal area as well as other factors. Consult your Isuzu dealer for more detailed information. Vehicle is speed limited to 100 km/h.

ISUZU WARRANTIES

STANDARD ¹	
New Vehicle	3 years • 500,000km • 6,500 hours
Cab Perforation Corrosion	3 years • unlimited km
Engine ²	5 years • 750,000 km • 10,000 hrs
Isuzu Assist: 24 hour roadside assistance (3 years, unlimited km)*	

ORDER CODES

Model	Code
EXY 240-460 PM	EH-EXYCA-B18

¹ Subject to the conditions outlined in the IAL New Vehicle Warranty, the Isuzu EXY model carries a standard factory warranty which covers the owner: (i) for the entire vehicle, for the first 36 months or 500,000 km or 6,500 hrs (whichever comes first), (ii) against cab perforation corrosion, for 36 months and unlimited kilometres. ² Engine Warranty in the 4th and 5th year is limited to cylinder block, cylinder head and crankshaft. *Valid for three years from the date of new vehicle purchases. All Isuzu warranties are subject to mandatory prescribed terms under Australian Consumer law including customer guarantees. For more details visit the Isuzu website which explains Isuzu warranties in more detail, or alternatively contact your local dealer. All warranties commence from date of delivery.

ISUZU AUSTRALIA LIMITED ABN 97 006 962 572 ("IAL"). The information in this spec sheet was correct at time of printing, but all measurements, specifications and equipment are subject to change without notice. Some equipment may have been changed and/or is available at extra cost. IAL may make changes at any time without notice, in prices, colours, materials, equipment and models. IAL makes all reasonable attempts to ensure the availability of all vehicles and equipment. The information in this spec sheet is general in nature. Your Isuzu dealer can confirm all measurements, specifications and vehicle / equipment availability upon request. To the extent permitted by the law, IAL is not liable to any person as result of reliance on the content of this spec sheet.

We
share
the
load.

ISUZU
RELIABILITY IS EVERYTHING