

# 650

**FSR 650 CREW CAB**

**GVM 11,000 kg  
GCM 16,000 kg  
WHEELBASE 4,720 mm**

## ISUZU 6BG1 ENGINE PERFORMANCE

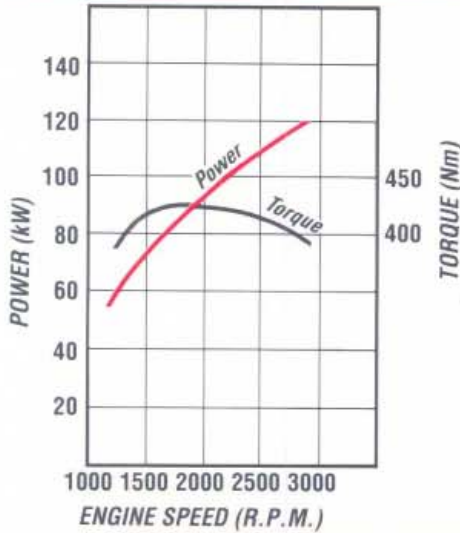

- Type: 6 Cylinder OHV diesel, four stroke, direct injection
- Bore x Stroke (mm) 105 x 125
- Displacement 6494 (cc)
- Compression ratio (:1) 17.0
- Output-Power (kW) 120 @ 2900 rpm (DIN Nett)
- Torque (Nm) 431 @ 1800 rpm (DIN Nett)

## DIMENSIONS

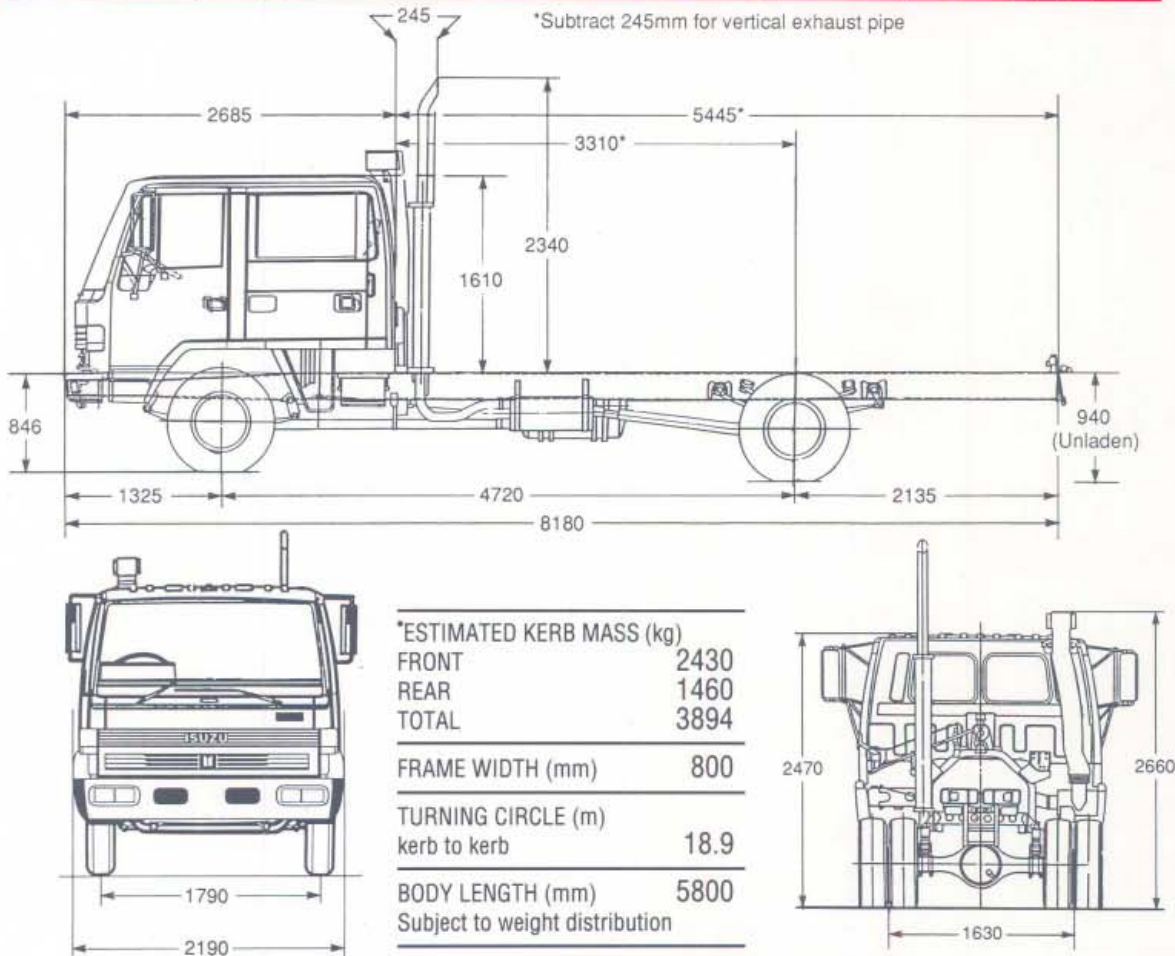

\*Chassis and cab with oil, water and fuel tank containing 10 litres of fuel.

ISUZU-GENERAL MOTORS AUSTRALIA LTD A.C.N. 006 962 572

**12/50 WARRANTY.** Every Isuzu Truck is covered by the I-GM new vehicle warranty which covers your vehicle for the first 12 months or 50,000 kilometres.

PLEASE NOTE: as the policy of Isuzu-General Motors Australia Motors is one of continual product improvement, all specifications and equipment are subject to change without notice. Body illustrated are not standard. No I-GM dealer or other person is authorised or permitted to give or make any statement, assertion or undertaking in relation to the quality performance characteristics descriptions or fitness for any purpose of any I-GM product or in connection with the supply of any I-GM product which is at variance with any written statement assertion or undertaking on any of these subjects given or made by Isuzu-General Motors Australia Limited in its published sales literature, and the company excepts no liability for any such unauthorised action. Isuzu-General Motors Australia Limited has franchised dealers in many parts of Australia. For the sale of service parts and the provision of service to owners of I-GM products. Every endeavour is made to ensure that such dealers carry adequate stocks of service parts, and are equipped to provide satisfactory service, but makes no promise, other than that contained in the New Vehicle Warranty given by Isuzu-General Motors Australia Limited, that such parts or service facilities will be available, or available at any specific location or any particular time.

CT2921-10/91

ISUZU







# 650

FSR 650 CREW CAB

**ORDERING CODE**  
**8EK03-321**

## ENGINE - ISUZU 6BG1

### Lubrication:

- Pressure feed lubrication with full flow paper element filter, oil cooler. Oil capacity 12.5 litres including filter.

### Cooling System:

- Six blade plastic cooling fan with thermatic clutch, size 475 mm diameter.
- Tube and corrugated fin pressure type radiator. Size(mm) 622h x 559w x 53t. Frontal area 0.348 m<sup>2</sup> with bell mouth fan shroud.

## FUEL SYSTEM

- Two stage paper element air cleaner, Donaldson 9" with high vertical air intake stack and rain head.
- In line plunger, Bosch 'A' type fuel injection pump with mechanical all speed governor.
- In line paper filter. See through water separator with drain cock.
- Fuel tank capacity 200 litres.
- Horizontal exhaust muffler with vertical stack.

## CLUTCH

- Hydraulic control. Dry single plate with coil type cushioning springs, 325 mm (13") diameter. Lining area 966 cm<sup>2</sup>, (both sides)

## TRANSMISSION ISUZU MBG6P

- Six speed overdrive, constant mesh, synchromesh on gears 2-6. Oil capacity 6.1 litres
- **Gear Ratios:1**

<b>1st</b>	6.378	<b>5th</b>	1.000
<b>2nd</b>	3.627	<b>6th</b>	0.787
<b>3rd</b>	2.239	<b>Reverse</b>	5.835
<b>4th</b>	1.452		

- Maximum geared speed 106 km/h
- Two piece propeller shaft, 90 mm diameter.
- **Length:**

<b>1st section</b>	1,438mm
<b>2nd section</b>	1,299mm

## REAR AXLE - CAPACITY 7,700kg

- Banjo type, fully floating, single reduction.

Ratio:	6.143:1
Hypoid type ring gear:	365 mm diameter
Oil capacity:	6.5 litres

## REAR SUSPENSION - CAPACITY 11,020kg

- Semi-elliptical, alloy steel, tapered multi-leaf springs. Fully wrapped eye with greasable shackles.
- Size - length x width x thickness:

Main:	1300 x 70 x 12 mm - 8 leaves
Auxiliary:	850 x 70 x 11 mm - 2 leaves
	850 x 70 x 12 mm - 5 leaves

## FRONT AXLE - CAPACITY 3,400kg

- Reverse Elliot I-beam type. King pin diameter 35 mm with cylindrical roller thrust bearing.

## FRONT SUSPENSION - CAPACITY 5,100kg

- Semi elliptical, alloy steel, tapered, multi-leaf springs. Fully wrapped eye with greasable shackles.
- Size - length x width x thickness:

	1350 x 70 x 11 mm - 1 leaf
	1350 x 70 x 12 mm - 6 leaves

- Hydraulic, Double acting, telescopic shock absorbers.

## STEERING

- Fully integral, power assisted, recirculating ball type. Gear ratio 22.4:1. Turns lock to lock 4.3
- Gear driven vane type oil pump, oil capacity 2.0 litres.

## BRAKES

- Air over hydraulic, dual circuit, front two leading, rear dual two leading.
- Drum diameter, front 400mm, rear 410mm. Total lining area 3972 cm<sup>2</sup>.
- Spring parking brake acting on rear wheels.
- Butterfly, air controlled, exhaust brake system, activation switch on wiper/washer control stalk.

## CHASSIS FRAME

- Parallel rail, ladder type, channel section, cold riveted.
- Side member dimensions - 225 x 70 x 6 mm
- Frame reinforcement angle section 203 x 64 x 4.5mm at cab back. 213 x 64 x 3.2mm at rear axle.
- High tensile steel, HT55 weldable frame material.

## WHEELS AND TYRES

- 6.50 T x 20 - 8 stud disc wheels front and rear, 22 mm bolt size.
- 8.25R 20 - 14 ply Michelin XZP tubed radial tyres front and rear. Number of tyres 7, including spare.
- Winch type spare wheel carrier.

## ELECTRICAL SYSTEM

- Batteries 2 x 12 volt - 53 Amp/h, negative earth.
- Alternator 24 volt - 40 Amp.
- Starter motor 24 volt - 4.5 kW output.
- Rear stop and tail lamps and licence plate lamp with long leads for variable body mounting. Turn signal side indicator lamps for body mounting.

## CAB EXTERIOR

- All steel, power tilt four door cab, cation electro deposition primer.
- Heavy duty bumper bar with four rectangular halogen head lamps inset.
- Combination turn signal and park lamps.
- West Coast type rear view mirrors with clearance lamps.

- Laminated windshield 2 speed wiper with intermittent mode and washers.
- Front side quarter vent windows.
- Corrosion resistant non slip cab front entry steps.
- Steel rear entry steps.
- Exterior grab handles on 'B' and 'C' pillars.
- Tool kit with 10,000 kg capacity jack.

## CAB INTERIOR

- Air suspension driver's seat, reclining with seat slide and height control.
- Outboard passenger seat, folding centre seat back with lockable compartment and snack tray.
- Rear 4 seater bench seat.
- All outboard seats have lap/sash seat belts with emergency locking retractor, inboard seats have lap belts.
- Vinyl seat material, padded roof lining and heavy duty vinyl floor mat.
- Overhead parcel shelf with driver and passenger sunvisors.
- Easy entry grab handles on 'A' and 'B' pillars full length grab rail for rear passengers.
- Soft feel urethane steering wheel.
- Heater demister with 4 speed fan, 4 outlet vents to screen, 5 fascia outlets, 5 foot outlets.
- AM/FM radio with digital clock.
- Front and rear compartment lamps.

## INSTRUMENTATION

- Speedometer, odometer and tachometer.
- Gauges for coolant temperature, fuel level and brake air pressure.
- Dash illumination control.

## INDICATOR LAMPS

- Turn signals, parking brake on, high beam on exhaust brake engaged, brake fluid level.

## WARNING LAMPS

- With warning bulb checking switch
- Battery charge, oil filter clogged, oil pressure, low air pressure, brake system, air cleaner clogged, stop and tail lamp failure.

## SWITCHES

- Left side combination switch for exhaust brake, wipers and washers.
- Hazard lamp switch.
- Right side combination switch for headlamps, turn signals and headlamp dip.
- Key operation for engine stop and start, external engine crank switch for service when cab is tilted.
- 24 Volt 2 pin accessory plug on centre fascia panel.
- Three way switch for interior lamp activated by driver and passenger doors.