

ISUZU

FRR500

SHORT/MEDIUM/LONG

MAY 1998

Proj 341

ADR 35/01

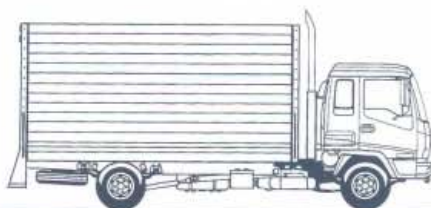

ENGINE ISUZU 6HH1-N

Type:	6 cylinder, overhead camshaft, four stroke, direct injection, diesel.
Bore x Stroke:	115 mm x 132 mm.
Displacement:	8226cc.
Compression Ratio:	18.5 : 1.
Output - Power:	129 kW @ 2800 RPM. (ISO 1585)
Torque:	490 Nm @ 1700 RPM. (ISO 1585)

COOLING SYSTEM

- 6 blade plastic cooling fan 500mm diameter with thermatic fan clutch. Corrugated fin radiator with fan shroud. Frontal area 3820 cm². Coolant capacity 23.3 litres.

CLUTCH

- Hydraulic control dry single plate. 355 mm (14") diameter.
- Asbestos free lining material. Total lining area (both sides) 966 cm².

TRANSMISSION: ISUZU MBJ5J

- 5 speed direct drive, constant mesh with synchromesh on gears 2-5. Oil capacity 4.4 litres.
- Gear ratios (: 1)

1st	2nd	3rd	4th	5th	Rev
6.378	3.627	2.307	1.452	1.000	6.595

- Maximum geared speed 108 km/h.
- 2 piece propeller shaft, 90 mm diameter.

REAR AXLE: ISUZU R077 CAPACITY 7700 KG

- Banjo type, fully floating, single reduction. Ratio 4.33 : 1
- Hypoid type ring gear, 343 mm diameter. Oil capacity 5.5 litres.

FRONT AXLE: ISUZU F036 CAPACITY 3600 KG

- Reverse Elliot I-beam type. King Pin diameter 35 mm with cylindrical roller thrust bearing.

BRAKES

- Air over hydraulic, dual circuit, front two leading, rear dual two leading. Drum diameter front and rear 320 mm. Total swept area 5127 cm².
- Air dryer.
- Asbestos free lining material.
- Mechanical park brake, internal expanding at rear of transmission.

AIR INTAKE SYSTEM

- Donaldson 11" two stage with vertical air intake stack and rain head.

ELECTRICAL SYSTEM

- Batteries - 2 x 12 volt / 65 amp/h, negative earth.
- Alternator - 24 volt / 40 amp.
- Starter motor - 24 volt / 4.5 kW.
- Rear stop and tail lamps and licence plate lamp with long leads for variable body mounting.

EXHAUST SYSTEM

- Horizontal exhaust muffler with vertical exhaust stack.
- Exhaust brake, air controlled.

FUEL SYSTEM

- In line plunger, Bosch 'AD' type fuel injection pump with mechanical all speed governor. In line filter, see through water separator with drain cock. Single fuel tank, capacity 180 litres.

STEERING

FRONT

- Fully integral power assisted recirculating ball type.
- Gear ratio 16.1 ~ 18.8 : 1. Turns lock to lock 4.1.
- Gear driven vane type oil pump. Oil capacity 1.5 litres.

SUSPENSION

FRONT

- Semi-elliptical, alloy steel tapered multi-leaf springs. Fully wrapped eye with greasable shackles.
- Length x Width x Thickness x No. leaves
1200mm x 70mm x 10mm x 8
- Hydraulic, double acting, telescopic shock absorbers.

REAR

- Semi-elliptical, alloy steel tapered multi leaf springs. Fully wrapped eye with greasable shackles.

	Length	x	Width	x	Thickness	x	No. leaves
Main:	1300	x	70mm	x	11mm	x	8
Aux:	850	x	70mm	x	10 mm	x	3
	850	x	70mm	x	11mm	x	4

WHEELS AND TYRES

WHEELS

- 6.00 x 17.5, 6 stud disc wheels, 225/90R17.5-14 ply tubeless radial tyres front and rear.

TYRES

- Number of wheels and tyres 7, including spare. Winch type spare wheel carrier.

CHASSIS FRAME

- Parallel rail, ladder type channel section, cold rivetted.
- Straight frame for easy body mounting. Frame width 840 mm.
- Side member dimensions 225mm x 70mm x 6mm.
- Frame reinforcement angle section 203mm x 64mm x 4.5mm at back of cab.
- Material HT540A high tensile, weldable steel.

ISUZU GENERAL MOTORS AUSTRALIA LTD. A.C.N. 006 962 572 24/100,000 WARRANTY. Subject to the conditions of the I-GM New Vehicle Warranty, every Isuzu Truck carries a warranty which covers your vehicle for the first 24 months or 100,000 kms (whichever comes first). A 36 months or 150,000 kms (whichever comes first), power train warranty runs concurrently with the new vehicle warranty, as does a 36 months unlimited kilometres anti-rust warranty. PLEASE NOTE: as the policy of I-GM is one of continual product improvement, all specifications and equipment are subject to change without notice. Any body illustrated is not standard equipment. No I-GM dealer or other person is authorised or permitted to give or make any statement, assertion or undertaking in relation to the quality, performance, characteristics, descriptions or fitness for any purpose of any I-GM product or in connection with the supply of any I-GM product which is at variance with any written statement, assertion or undertaking on any of these subjects given or made by I-GM in its published sales literature, and the company accepts no liability for any such unauthorised action. I-GM has franchised dealers in many parts of Australia, for the sale of service, parts and the provision of service to the owners of I-GM products. Every endeavour is made to ensure that such dealers carry adequate stocks of service parts and are equipped to provide satisfactory service, but makes no promise, other than that contained in the I-GM new vehicle warranty, that such parts or service facilities will be available or available at any specific location or at any particular time. A word about this specification sheet. We have tried to make it as comprehensive and factual as possible. However, since the time of printing some of the information you will find here may have been updated. Also, some of the equipment shown or described through this specification sheet may have been changed and/or is available at extra cost. And the right is reserved to make changes at any time without notice, in prices, colours, materials, equipment and models. Your I-GM dealer has details and before ordering, you should ask him/her to bring you up to date.

LUBRICATION SYSTEM

- Pressure feed lubrication with combination full flow and partial flow by-pass filter. Plate type oil cooler in water jacket. Oil capacity 13.5 litres including filter.

CAB EXTERIOR

- All steel cab with welded strengthening ribs and side door impact beams. Torsion bar assisted manual tilt to 45°.
- 4 silicone filled rubber cab isolators.
- Cation electrodeposition primer.
- Bumper bar with step holes and footplate.
- Halogen headlamps, hinged for easy bulb replacement. Park lamps and cab clearance lamps
- Turn signal lamps in front bumper and doors.
- 2 speed wiper/washer with variable intermittent mode. Triple washer jets mounted on wiper arms.
- Tinted, laminated windscreen; tinted, toughened side and rear glass.
- West Coast type rear view mirrors.
- Alloy non-slip cab entry steps.
- Lift up front access panel for clutch and windscreen washer fluids, cab air filter screen.
- Engine and brake fluid check points at rear of cab.

CAB INTERIOR

- Fully trimmed cab interior with cloth seat facings, formed roof lining. Overhead storage lockers. Driver and passenger sun visors.
- Pull out drinks holder in centre fascia, cigarette lighter with ash trays in doors.
- Driver's seat with mechanical suspension and 3 way lumbar support. Adjustment for seat back recline, seat slide and weight control.
- Outboard reclining passenger seat with under-seat storage drawer. Folding centre seat back with lockable compartment and tray.
- Outboard lap/sash seat belts with emergency locking retractors, centre lap seat belt.
- Tilt/telescopic adjustable steering column, soft feel urethane steering wheel.
- Easy entry grab handles on 'A' pillars.
- Heater demister with 4 speed fan, 4 outlet vents to screen, 5 fascia outlets, 5 foot outlets, demister ducts to door glass.
- AM/FM radio cassette with digital clock, dash mounted.
- DIN standard aperture in dash for CB radio.
- Park brake activation lever at left side of driver's seat.
- Rear vision mirror.
- Passenger side assist grip.
- Driver's left foot rest.
- Cab exhaust vents rear/upper cab.
- Business card clip. Coat hook at rear of cab.
- Elastic mesh pocket on driver's door.

CONTROLS

- Left side combination stalk switch for exhaust brake, windscreen wipers and washers, hazard lamps.
- Right side combination stalk switch for headlamps, high beam and turn signals.

- Engine idle speed adjust control.
- Key operation for engine start and stop, external engine crank switch for service when cab is tilted.
- 3 way switch for interior lamp activated by driver and passenger doors.
- 24 volt – 2 pin accessory plug in centre console.

INSTRUMENTATION

- GAUGES: Speedometer, odometer, tripmeter and tachometer. Gauges for coolant temperature, fuel level and brake air pressure.
- INDICATOR LAMPS: Turn signals, parking brake on, high beam on, exhaust brake engaged. Reversing lamp and beeper.
- WARNING LAMPS: With warning bulb check switch. Battery charge, oil pressure, low air pressure, brake system, stop and tail light failure.

TOOLS

- Lockable tool box. 7000kg capacity jack and wheel changing tools, tool kit.

MODEL, CODES & RATINGS

MODEL	WHEELBASE	GVM	GCM	ORDERING CODE
FRR 500 SHORT	3780mm	10,400kg	14,890kg	8FB02-261
FRR 500 MEDIUM	4250mm	10,400kg	14,890kg	8FC02-261
FRR 500 LONG	4850mm	10,400kg	14,890kg	8FD02-261

KERB MASS* (kg)

	Front	Rear	Total
FRR 500 SHORT	2,100	940	3,040
FRR 500 MEDIUM	2,090	990	3,080
FRR 500 LONG	2,125	1,010	3,135

*Estimated mass of chassis cab with oil, water and fuel tank containing 10 litres of fuel. Excluding spare wheel and tools.

DIMENSIONS (mm)

	FRR 500 SHORT	FRR 500 MEDIUM	FRR 500 LONG
WB Wheelbase	3,780	4,250	4,850
OAL Overall Length	6,570	7,220	8,170
ROH Rear Overhang	1,605	1,785	2,135
CA Cab To Axle	2,985	3,455	4,055
CE Cab To End Of Frame	4,590	5,240	6,190
FFH Front Frame Height, Unladen	800	800	795
FFH Front Frame Height, Laden	770	770	770
RFH Rear Frame Height, Unladen	875	875	910
RFH Rear Frame Height, Laden	809	809	845
Turning Circle (Kerb To Kerb)	12.2m	13.4m	14.9m
Nominal Max. Body Length*	4,850	5,600	6,560

*Except Turning Circle: metres. *Subject to weight distribution

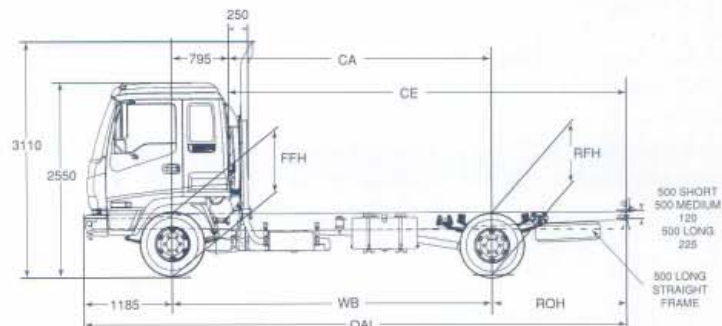
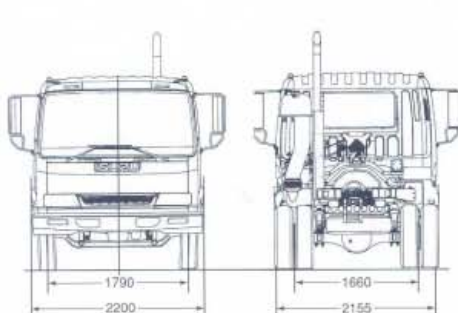

FRR500

SHORT/MEDIUM/LONG

ISUZU

RELIABILITY IS EVERYTHING