

Gigamax EXY 510



AUSTRALIA'S TOP SELLING TRUCK BRAND SINCE 1989. Truck tracker 2009.

AT A GLANCE

GVM	26,000 kg
GCM	70,000 kg
Power	382 kW @ 1,800 rpm
Torque	2,255 Nm @ 1,300 rpm

ADVANCED TECHNOLOGY

- Emissions: JNLT 05 - meets ADR80/03
- Driver airbag with seatbelt pretensioner
- Electronic Braking System (EBS) and Voith retarder
- Alcoa Aluminium wheels
- Cross and interaxle locks
- ECE-R29 compliant cab
- Optional Front Underrun Protection Device (FUPD)
- Isri 6860 seat with integrated seatbelt
- 16 speed Automated Manual Transmission



RELIABILITY IS EVERYTHING ISUZU

Driveline & Chassis Specifications

ENGINE SİTEC SERIES II 510 (ISUZU 6WG1-TCS)

- Type:** 6 cylinder 24 valve SOHC
- Displacement:** 15,681 cc
- Compression Ratio:** 16.5:1
- Bore x Stroke:** 147 mm x 154 mm
- Max power (DIN - NET):** 382 kW (512 HP) @ 1,800 RPM
(JIS Gross): 396 kW (531 HP) @ 1,800 RPM
- Max torque (DIN-NET):** 2,255 Nm (1,663 lb.ft) @ 1,300 RPM
(JIS Gross): 2,334 Nm (1,721 lb.ft) @ 1,300 RPM
- Induction system:** High capacity turbocharger with air-to-air intercooler.
- Fuel injection:** Direct injection high pressure common rail system.
- Emission control system:** Four-stage electronically controlled cooled EGR with exhaust Diesel Particulate Diffuser (DPD). ADR 80/03 (J-NLT05) compliant.

CLUTCH

- Twin plate 15.5".
- Fully automated control or manual control available at crawl speed only.

TRANSMISSION

Isuzu MJX 16P

- 16 speed constant mesh Automated Manual Transmission (AMT) with both automatic and manual operation modes.

• Gear ratios (:1)

1st	2nd	3rd	4th	5th	6th
14.012	11.431	9.931	8.038	6.839	5.535
7th	8th	9th	10th	11th	12th
4.583	3.709	3.057	2.474	2.167	1.754
13th	14th	15th	16th	Rev 1	Rev 2
1.492	1.207	1.000	0.809	12.582	10.184

AXLES

Front: MERITOR

- MFS73 reverse Elliot I-beam. 7,300 kg capacity.

Rear: MERITOR

- RT-46-160GP tandem axle set. 21,000 kg capacity.
- Integral oil pump.
- Driver controlled inter-axle lock and cross locks on both axles.
- Drive ratio: 4.10:1

SUSPENSION

Front:

- Single stage alloy steel taper leaf springs.
- Double acting hydraulic shock absorbers. Stabiliser bar.

Rear:

- Isuzu 8-bag electronically controlled air suspension system.
- Double acting hydraulic shock absorbers. Stabiliser bar.
- RFCN: 2044

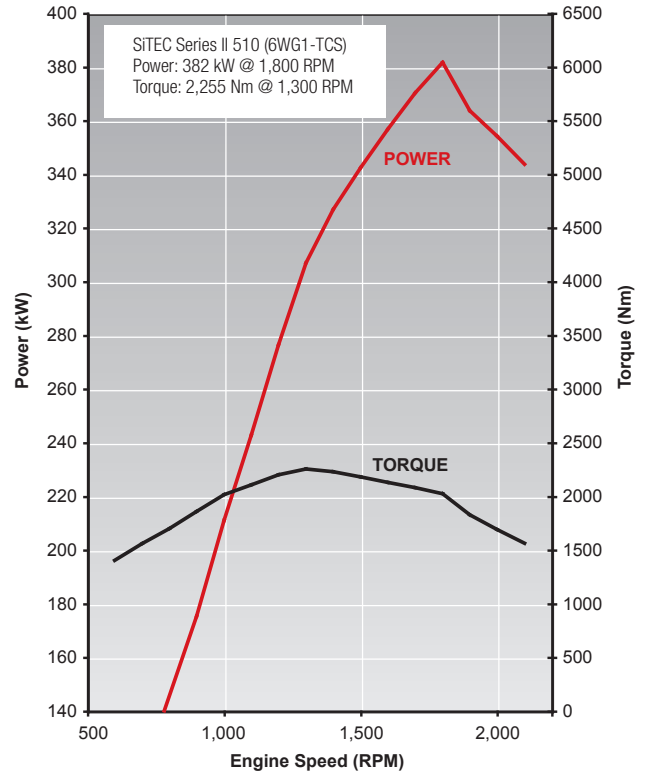

BRAKES

- Meritor ELSA dual circuit full air front and rear disc brakes.
- EBS (Electronic Braking System) - includes ABS and ASR (traction control).
- Spring park brake acting on all rear wheels.
- Air controlled exhaust brake.
- Voith hydrodynamic retarder.
- Air dryer.
- Trailer brake connection at rear of cab.

STEERING

- Power assisted recirculating ball steering.
- Gear ratio: 22.4:1
- Turns lock to lock: 4.4
- Maximum angle: 40° (inside wheel) / 32.2° (outside wheel)

WHEELS AND TYRES

- 22.5 x 8.25 ten stud ISO standard Alcoa aluminium wheels.
- **Steer axle:** 295/80R22.5 152/148M Michelin XZE2 Tubeless
- **Drive axles:** 11R22.5 148/145L Michelin XDE2 Tubeless
- Maximum tyre rating:
 - Steer axle: 7,100 kg
 - Tandem drive axle set: 23,200 kg
- Spare wheel rim supplied.

CHASSIS FRAME

- Cold rivetted ladder frame. HT540A high tensile weldable steel sidemembers.
- Frame dimensions:
 - Side rail (mm): 285 x 85 x 8.0
 - Rear frame width (mm): 850
- Turntable angles fitted.

FUEL TANK

- Frame mounted 1 x 550L and 1 x 450L aluminium fuel tanks.
- Lockable fuel caps.

ELECTRICAL SYSTEM

- 24 volt electrical system.
- 90 amp alternator.
- 24 volt, 7.0 kW starter motor.
- 2 x 145G51 (754 CCA) batteries connected in series.
- 24 volt supply to trailer electrics.

Cabin Specifications and Appointments**CAB EXTERIOR**

- All steel high roof cab with electro-hydraulic cab tilt.
- Complies with ECE-R29 cab strength standard.
- Full floating cab with air suspension and hydraulic shock absorbers.
- Heavy duty non slip entry steps.
- 90° opening internally reinforced front doors.
- Water spray suppression guards and front mudflaps.
- Laminated windscreen with shade band.
- Two speed windscreen wipers with variable intermittent wipe mode.
- Halogen headlamps. Bumper mounted turn signals and foglamps. Additional door mounted side indicator lamps.
- Combination brake, turn, reverse and marker lamps, registration plate illumination lamps. Reverse alarm.
- Roof-mounted clearance lamps.
- Heated and powered exterior main mirrors with flat glass and additional powered convex "spot" mirrors.
- Body coloured grille.
- Body coloured steel air dam bumper.
- Trailer air and electrical connectors at rear of cab.

CAB INTERIOR

- Isri 6860 air suspension driver's seat with pneumatic lumbar support, height, rake and automatic weight adjustment.
- Front passenger adjustable bucket seat.
- 3-point lap sash seatbelts in all outboard seating positions. Driver seatbelt with pretensioner integrated with driver seat.
- ADR 42 compliant sleeper with mattress.
- Cab window curtain.
- Driver airbag.
- Door and roof pillar entry assist grips.
- Full interior trim, padded roof lining and carpet floor covering. Overhead front storage compartments.
- Tilt/Telescopic adjustable steering column, leather trimmed steering wheel.
- Electric windows.
- Central locking with remote keyless entry.
- 24V cigarette lighter. 12V electrical accessory sockets.
- Front door mounted storage pockets and ashtrays.
- Large centre console with storage compartments and heat/cool box.
- Fully integrated auto control air conditioning and heater/demister with 4-speed fan and outlets for windscreen, side windows, face and floor.

- Fluorescent type interior lamp with On/Door/Off switch.
- 2 DIN, two speaker radio/CD multimedia unit with 4.8" LCD touch screen and Bluetooth. Provision for SD card, USB and 3.5 mm plug inputs.

DRIVER CONTROLS

- Key-operated engine start/stop and steering lock. Engine idle speed control.
- DPD regeneration.
- Interaxle lock and cross lock engage switches.
- Hand held pendant for rear suspension raise and lower.
- Hi/lo horn control switch.
- AMT power/economy, skip shift and manual control mode switches.
- **Left side combination stalk:** Windscreen wipers, washer, exhaust brake and hazard lamps.
- **Right side combination stalk:** Turn signals, headlamps, cruise control.
- Trailer brake control valve.
- Four stage retarder control lever.

INSTRUMENTATION

- Electronically driven speedometer and tachometer. Digital odometer with integrated dual tripmeter. Engine coolant temperature, fuel level and air pressure gauges.
- **Warning lamps:** Check engine, oil pressure, ABS, SRS airbag, alternator charge, service brakes, park brake, trailer brake, seat belt unfastened, low air pressure, cab suspension, suspension height adjust, check AMT.
- **Indicator lamps:** High beam, fog lamps, DPD status, exhaust brake, retarder, turn signals, cruise control, AMT shift mode selection.
- Gear selection display.
- Multi information display. Shows instantaneous, average and idling fuel consumption, time/day/date, voltmeter, and vehicle systems status.

OPTIONS AND GENUINE ACCESSORIES

Include the following (extra cost, request a brochure and further details from your Isuzu dealer):

- Satellite navigation - integrates with multimedia unit and includes NAVTEQ mapping.
- Up to three audio/visual reversing cameras - integrates with multimedia unit.
- FUPD Bumper Bar - complies with ECE-R93.
- Standard Bullbar.
- FUPD Bullbar - complies with ECE-R93.
- Air deflector.

ISUZU

SPECIFICATIONS

Weights (kg)

Models	Ratings*		Loading Limit* (at ground)		Cab Chassis Mass#		
	GVM	GCM	Front	Rear	Front	Rear	Total
Gigamax EXY 510 Premium	26,000	70,000	7,100	21,000	4,740	3,565	8,305

* Vehicle ratings and front/rear weight limits are subject to government regulatory requirements and weight distribution analysis. Consult your Isuzu dealer to select the correct vehicle for your specific application.
Cab chassis only and including 10 litres of fuel.

Dimensions (mm)

Models	WB	OAL	FOH	ROH	EA	CE	RT	ORT	CH	FFA (unladen)	RFA (unladen)	RFH (unladen)	Turn Circle (m)
													KERB TO KERB
Gigamax EXY 510	3,950	6,870	1,400	1,520	2,530	4,706	1,850	2,440	3,210	920	1,005	1,005	14.8

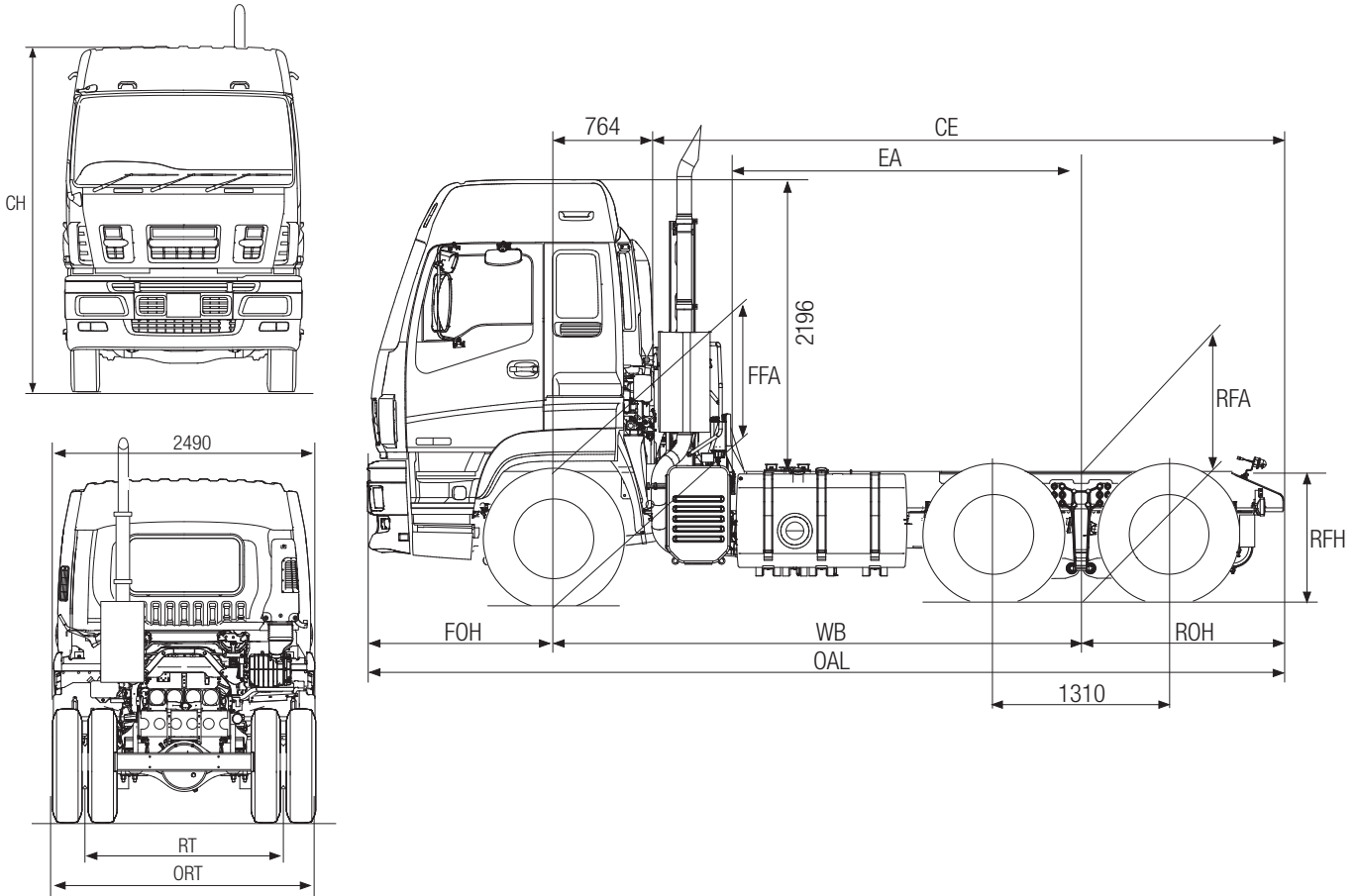

Performance (calculated - typical paved road)

	Geared Speed* (top gear at peak power engine RPM)	Low Speed Gradeability (lowest forward gear assuming no wheel slip)	Engine Speed (top gear at 100 km/h)
Gigamax EXY 510	At 70,000 kg GCM 105 km/h @ 1,800 RPM	33 %	1,715 RPM

* Maximum speed achievable depends on vehicle frontal area as well as other factors. Consult your Isuzu dealer for more detailed information. Vehicle is speed limited to 100 km/h.

Isuzu Warranty

New Vehicle ¹	3 years 500,000 km 6,500 hrs
Cab Perforation Corrosion ¹	3 years Unlimited km
Engine ²	5 years 750,000 km 10,000 hrs

¹ Subject to the conditions outlined in the IAL New Vehicle Warranty, the Isuzu EXY model carries a standard factory warranty which covers the owner: (i) for the entire vehicle, for the first 36 months or 500,000 km or 6,500 hrs (whichever comes first). (ii) against cab perforation corrosion, for 36 months and unlimited kilometres. ² Engine Warranty in the 4th and 5th year is limited to cylinder block, cylinder head and crankshaft.

Order Codes

Model	Code
Gigamax EXY 510 Premium	EH-EXYDB-F01

ISUZU AUSTRALIA LIMITED ABN 97 006 962 572 ("IAL"). The information in this brochure was correct at time of printing, but all measurements, specifications and equipment are subject to change without notice. Some equipment may have been changed and/or is available at extra cost. IAL may make changes at any time without notice, in prices, colours, materials, equipment and models. IAL makes all reasonable attempts to ensure the availability of all vehicles and equipment. The information in this brochure is general in nature. Your Isuzu dealer can confirm all measurements, specifications and vehicle / equipment availability upon request.

July 2009. ARK0434

RELIABILITY IS EVERYTHING **ISUZU**