



ISUZU JCS 420

4 x 4 CUSTOM CREW CAB

GMH MODEL: FTS 12H
ORDERING CODE:
8DNO2 & V6R

STANDARD GVM (on or off road)	11000 kg
STANDARD GCM (on road)	15000 kg
TARE MASS (est)	4210 kg

DRIVELINE SPECIFICATION

ENGINE SPECIFICATION

Model: ISUZU 6BG1
 Type: 6 cylinder OHV diesel
 Displacement: 6494cc
 Max. Power: 120 kW @ 2900 rpm
 Max. Torque: 431 Nm @ 1800 rpm
 Bore and Stroke: 105 x 125 mm
 Compression ratio: 170:1
 RAC rating: 41.0

TRANSMISSION

Model: ISUZU MBG5C
 Type: 5 speed direct drive
 Gear ratios (to 1)

1st	6.890
2nd	3.918
3rd	2.419
4th	1.569
5th	1.000
Rev	6.304

2 speed transfer case
 1.000/2.091.

AXLE, FRONT

Capacity: 3900 kg.
 Split Type, fully floating, single reduction, spiral bevel gear Ratio: 5.57:1 with free wheeling hubs.

AXLE, REAR

Single speed. Capacity: 9200 kg.
 Type: Banjo, fully floating single reduction, hypoid gear. Non-spin differential. Ratio: 5.57:1.

WHEELBASE
 4200mm

CHASSIS RATINGS

GROSS COMBINATION and GROSS VEHICLE MASS RATING:

Estimated kerb mass (chassis and cab with oil, water and full fuel tank). (kg) & spare tyre.

GVM (kg)	GCM (kg)	Tyres	Front	Rear	Total
11,000	15,000	9.00 x 20.12 ply (lug)	2655	1830	4485

DIMENSIONS

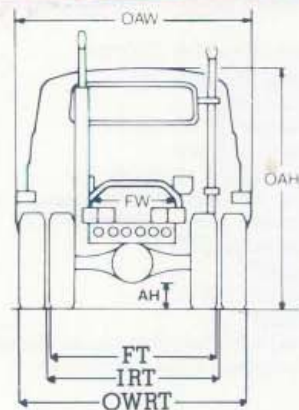
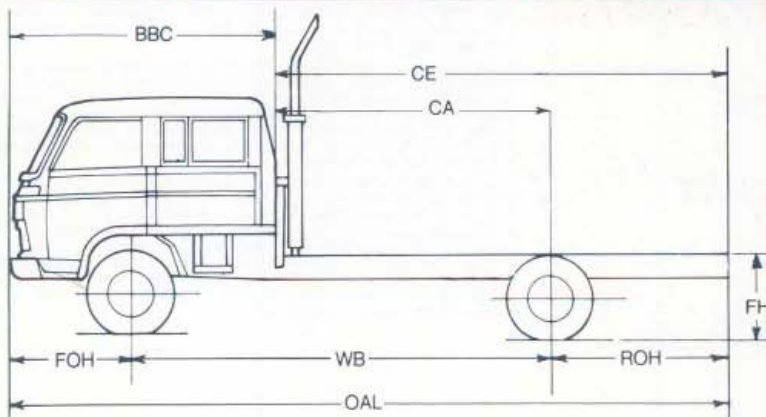

LENGTHS:

		(mm)
Overall length	OAL	7360
Wheelbase	WB	4200
Cab to axle	CA*	2795
Cab to end of frame	CE*	4695
Front Overhang	FOH	1260
Rear Overhang	ROH	1900
Bumper to Back of Cab	BBC	2665

HEIGHTS:

Overall height (approx)	OAH	2645
Rear axle clearance (approx)	B	265

TURNING CIRCLE:

Kerb to Kerb	(m)	18.8
--------------	-----	------

WIDTHS:

Overall width	OAW	2370
Frame width (rear)	FW	800
Front track	FT	1735
Inside rear track	IRT	1740
Outside rear track	OWRT	2310

*CA & CE dimensions are effectively reduced by 300mm with fitment of vertical air intake stack and exhaust



ISUZU
 Reliability is everything.

ISUZU JCS 420 CUSTOM

4 x 4 CUSTOM CREW CAB COMPONENT SPECIFICATIONS

AXLE, FRONT

Capacity: 3900 kg.
Split Type, fully floating single reduction, spiral bevel gear.
Ratio: 5.57:1 with free wheeling hubs.

AXLE, REAR

Single speed.
Capacity: 9200 kg.
Type: Banjo, fully floating single reduction, hypoid gear.
Non-spin differential. Ratio: 5.57:1.

BRAKES, SERVICE

Air over hydraulic, dual circuit, front-two leading, rear-dual two leading type. Exhaust brake.

BRAKE, PARKING

Type: Spring brake acting on rear wheels.

CABIN EXTERIOR

All steel tilt crew cab with laminated windshield. 2 speed windshield wiper/washer with intermittent setting. Westcoast type rear view mirrors. Dual round sealed beam headlamps. Vertical air intake stack. General hand tools and 10000 kg capacity jack. Spare wheel and tyre. Fog lamps. Front wheel step.

INTERIOR

Adjustable bucket driver seat with headrest. 2 front & 4 passenger rear seats. Sun visors. Roof, dash and floor ventilation points. AM radio. Full width glove compartment. Heater demister. Tilt and telescopic steering wheel.

INSTRUMENTATION

Speedometer with odometer, tachometer. Gauges for fuel, engine temperature and air pressure. Indicator lamps for park brake, alternator, oil pressure, headlamp/high beam, hazard warning, turn signals and exhaust brake on. Right combination switch incorporating headlamps, turn signal and dimmer. Fog lamp switch. Left combination switches for windshield washer and wiper, and exhaust brake. Clogged air filter warning light. Key operated engine stop.

CLUTCH

Type: Dry single plate with 6 cushioning springs, hydraulic operated.
Size: Outside diameter 350 mm.

ENGINE SPECIFICATION

Model: ISUZU 6BG1
Type: 6 cylinder OHV diesel
Displacement: 6494cc
Max. Power: 120kW @ 2900 rpm
Max. Torque: 431 Nm @ 1800 rpm
Bore and Stroke: 105 x 125 mm
Compression ratio: 170:1
RAC rating: 41.0
Vertical exhaust stack

LUBRICATION

Pressure feed with full-flow paper element filter. Oil cooler.
Capacity including filter: 13.5 litres

COOLING

Radiator: Tube and corrugated fin, pressured type.
Frontal area, radiator: 3480 sq. cm.
Core thickness: 53 mm

AIR CLEANER

Donaldson cyclopac 11" single stage type. Long vertical air intake stack.

FUEL SYSTEM

Injection pump: Bosch A type, with all speed mechanical governor. Pre fuel filter.
Fuel tank capacity: 200 litres.
Fuel/water sedimentor, metal fuel lines.

ELECTRICAL SYSTEM

Batteries: 2 x 12 volt 65 A/H
Alternator: 24 volt/40 amp
Starter: 24 volt/4.5 kW

FRAME

Type: Ladder type channel section
Frame width: Front 840 mm. Rear 800 mm
Side member dimensions: Depth x Width x Thickness:
225 mm x 70 mm x 6 mm
Frame reinforcement: Full length inner channel section 4.5 mm thick.

STEERING

Type: Recirculating ball with integral power assistance.
Gear Ratio 21.6:1.

SUSPENSION, FRONT

Semi-elliptical, alloy steel leaf springs with hydraulic double acting shock absorbers.
Size: Length x Width (mm) - 1300 x 70

SUSPENSION, REAR

Semi elliptical alloy steel leaf springs
Size: Length x Width (mm) 1420 x 80
Auxiliary: Length x Width (mm) 1000 x 80

TRANSMISSION

Isuzu MBG5C 5 speed direct drive.
Syncromesh on 2nd, 3rd, 4th, 5th gears.
Floor mounted remote control.
Ratios: (to 1)
1st 6.890 2nd 3.918 3rd 2.419 4th 1.569 5th 1.000
Reverse 6.304
Transfer Case: 2 speed (1.000/2.091:1)

WHEELS AND TYRES

Dual rear wheels
Wheels and rims: 700T x 20
8 stud disc wheels. Tyres: 9.00 x 20 - 12 ply (lugs)
Spare wheel and tyre

GMH 12/20 WARRANTY

Every Isuzu is covered by the GMH warranty which covers the vehicle for the first 12 months or 20,000 kilometres.

Major engine components and driveline components have additional extended warranty. Please consult your GMH/ISUZU dealer for complete and accurate details.

PLEASE NOTE: As the policy of General Motors-Holden's is one of continual product improvement, all specifications and equipment are subject to change without notice. Bodies illustrated are not standard.

No GMH Dealer or other person is authorised or permitted to give or make any statement or undertaking in relation to the quality performance characteristics descriptions or fitness for any purpose of any GMH product or in connection with the supply of any GMH product which is at variance with any written statement or undertaking on any of these subjects given or made by General Motors-Holden's Limited or General Motors-Holden's Sales Pty. Ltd. in its published sales literature, and neither company accepts any liability for any such unauthorised action.

General Motors-Holden's Limited and General Motors-Holden's Sales Pty. Ltd. have franchised dealers in many parts of Australia for the sale of service parts and the provision of service to owners of GMH's products. Every endeavour is made to ensure that such dealers carry adequate stocks of service parts, and are equipped to provide satisfactory service, but neither General Motors-Holden's Ltd. nor General Motors-Holden's Sales Pty. Ltd. makes any promise, other than that contained in the New Vehicle Warranty given by General Motors-Holden's Sales Pty. Ltd., that such parts or service facilities will be available, or available at any specific location or any particular time.

General Motors-Holden's Sales Pty. Ltd.

YOUR GMH ISUZU DEALER: