

# ISUZU

## SPECIFICATIONS

### Giga CXZ 415 6x4

### Giga CXY 415 6x4



CXY pictured

AUSTRALIA'S TOP SELLING TRUCK BRAND SINCE 1989.

#### AT A GLANCE

GVM	24,000 kg
GCM	54,000 kg
Power	309 kW @ 1,800 rpm
Torque	1,863 Nm @ 1,300 rpm

#### ADVANCED TECHNOLOGY

Emissions: Euro V / ADR 80/03	ECE-R93 compliant front underrun protection device (FUPD)
Driver airbag with seatbelt pretensioner	ISRI 6860 seat with integrated seatbelt
Anti-lock Braking System (ABS)	12 speed Automated Manual Transmission
Cross and inter-axle locks	
ECE-R29 compliant cab	



We  
share  
the  
load.

**ISUZU**  
RELIABILITY IS EVERYTHING

# Giga CXZ 415 6x4

# Giga CXY 415 6x4

## DRIVELINE AND CHASSIS SPECIFICATIONS

### ENGINE SITEC SERIES III 415 (ISUZU 6WG1-TCN2)

- Type:** 6 cylinder 24 valve SOHC  
**Displacement:** 15,681 cc  
**Compression Ratio:** 16.5:1  
**Bore x Stroke:** 147 mm x 154 mm  
**Max power (DIN - NET):** 309 kW (414 HP) @ 1,800 RPM  
**(JIS Gross):** 320 kW (429 HP) @ 1,800 RPM  
**Max torque (DIN-NET):** 1,863 Nm (1,374 lb.ft) @ 1,300 RPM  
**(JIS Gross):** 1,929 Nm (1,423 lb.ft) @ 1,300 RPM  
**Induction system:** High capacity turbocharger with air-to-air intercooler.  
**Fuel injection:** Direct injection high pressure common rail system.  
**Emission control system:** Cooled EGR with exhaust Diesel Oxidation Catalyst (DOC). ADR 80/03 (Euro V) compliant.

### CLUTCH

- Twin plate 15.5".
- Fully automated control or manual control available at crawl speed only.

### TRANSMISSION

#### Isuzu MJX 12P

- 12 speed constant mesh Automated Manual Transmission (AMT) with both automatic and manual operation modes.

- Gear ratios (:1)

1st	2nd	3rd	4th	5th	6th	7th
12.272	9.933	7.206	5.833	4.583	3.709	2.677
8th	9th	10th	11th	12th	Rev 1	Rev 2
2.167	1.572	1.272	1.000	0.809	10.967	8.876

### AXLES

#### Front: MERITOR

- FG941 reverse Elliot I-beam. 6,600 kg capacity.

#### Rear: MERITOR

- RT-46-160GP tandem axle set. 21,000 kg capacity.
- Integral oil pump.
- Driver controlled inter-axle lock and cross locks on both axles.
- Drive ratio: 3.91:1

### SUSPENSION

#### Front:

- Single stage alloy steel taper leaf springs.
- Double acting hydraulic shock absorbers. Stabiliser bar.

#### Rear: (CXZ 415)

- Taper leaf springs with Isuzu 6 rod and trunnion location system.

#### Rear: (CXY 415)

- Hendrickson HAS461 airbag, 20,865 kg capacity at ground.
- Outboard mounted double acting shock absorbers.

### BRAKES

- Meritor 'Q-Plus' dual circuit full air 'S-cam' front and rear drum brakes with auto slack adjusters.
- ABS.
- Front drum size: 419 x 152 mm
- Rear drum size: 419 x 178 mm
- Spring park brake acting on all rear wheels.
- Air controlled exhaust brake.
- Air dryer.
- Trailer brake connection at rear of chassis.

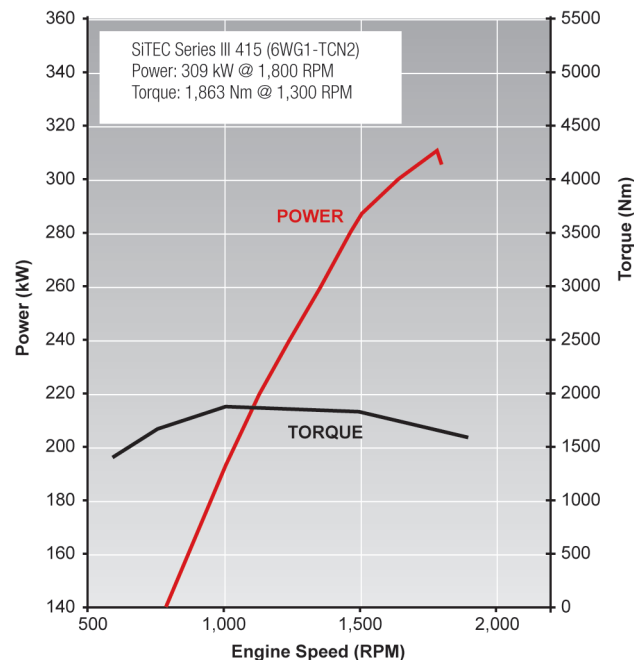

### STEERING

- Power assisted recirculating ball steering.
- Gear ratio: 22.4:1
- Turns lock to lock: 4.4
- Maximum angle: 40° (inside wheel) / 32.2° (outside wheel)

### WHEELS AND TYRES

- 22.5 x 8.25 ten stud ISO standard steel wheels
- Tyre size and load index:
  - Steer axle:** 295/80R22.5 152/148M Tubeless
  - Drive axles:** 11R22.5 148/145L Tubeless
- Tyre type:
  - Steer axle:** Michelin XZE2 Tubeless (except highway model), Michelin XZA2+ Energy Tubeless (highway model)
  - Drive axles:** Michelin XDE2 Tubeless (except highway model), Michelin XJE4 Mix Energy (highway model)
- Maximum tyre rating:
  - Steer axle:** 7,100kg
  - Tandem drive axle set:** 23,200kg
- Spare wheel rim supplied. Winch type carrier (except CXY short)

### CHASSIS FRAME

- Cold rivetted ladder frame. HT540A high tensile weldable steel sidemembers.
- Frame dimensions:
  - Side rail (mm): 285 x 85 x 8.0
  - Rear frame width (mm): 850

## FUEL TANK

- Frame mounted 400L aluminium fuel tank.
- Lockable fuel cap.

## ELECTRICAL SYSTEM

- 24 volt electrical system.
- 90 amp alternator.
- 24 volt, 7.0 kW starter motor.
- 2 x 145G51 (754 CCA) batteries connected in series.
- 24 volt supply to trailer electrics.

## CABIN SPECIFICATIONS AND APPOINTMENTS

### CAB EXTERIOR

- All steel standard height cab with electro-hydraulic cab tilt.
- Complies with ECE-R29 cab strength standard.
- Full floating cab with air suspension and hydraulic shock absorbers.
- Heavy duty non slip entry steps.
- 90° opening internally reinforced front doors.
- Water spray suppression guards and front mudflaps.
- Laminated windscreen with shade band.
- Two speed windscreen wipers with variable intermittent wipe mode.
- Halogen headlamps. Bumper mounted turn signals and foglamps. Additional door mounted side indicator lamps.
- Combination brake, turn, reverse and marker lamps, registration plate illumination lamps. Reverse alarm.
- Roof-mounted clearance lamps.
- Heated and powered exterior main mirrors with flat glass and additional powered convex "spot" mirrors.
- Body coloured grille.
- FUPD underun bar - complies with ECE R93.
- Body coloured steel bumper. Air dam type (highway model). Standard type (except highway model).

### CAB INTERIOR

- Isri 6860 air suspension driver's seat with pneumatic lumbar support, height, rake and automatic weight adjustment.
- Front passenger adjustable bucket seat.
- 3-point lap sash seatbelts in all outboard seating positions. Driver seatbelt with pretensioner integrated with driver seat.
- ADR 42 compliant sleeper with mattress.
- Sleeper compartment curtain.
- Driver airbag.
- Door and roof pillar entry assist grips.
- Full interior trim, padded roof lining and vinyl floor covering. Overhead front storage compartments.
- Tilt/Telescopic adjustable steering column, leather trimmed steering wheel.
- Electric windows.
- Central locking with remote keyless entry.
- 24V cigarette lighter. 12V electrical accessory sockets.
- Front door mounted storage pockets and ashtrays.
- Large centre console with storage compartments and heat/cool box.
- Fully integrated auto control air conditioning and heater/demister with 4-speed fan and outlets for windscreen, side windows, face and floor.
- Fluorescent type interior lamp with On/Door/Off switch.
- 2 DIN, two speaker radio/CD multimedia unit with 4.8" LCD touch screen and Bluetooth. Provision for SD card, USB and 3.5 mm plug inputs.

### DRIVER CONTROLS

- Key-operated engine start/stop and steering lock. Engine idle speed control.
- Inter-axle lock and cross lock engage switches.
- Rear suspension raise, lower and dump (CXY only).
- Hi/lo horn control switch.
- AMT power/economy, skip shift and manual control mode switches.
- **Left side combination stalk:** Windscreen wipers, washers, exhaust brake and hazard lamps.
- **Right side combination stalk:** Turn signals, headlamps, cruise control.
- Trailer brake control valve.

### INSTRUMENTATION

- Electronically driven speedometer and tachometer. Digital odometer with integrated dual tripmeter. Engine coolant temperature, fuel level and air pressure gauges.
- **Warning lamps:** Check engine, oil pressure, ABS, SRS airbag, alternator charge, service brakes, park brake, trailer brake, seat belt unfastened, low air pressure, cab suspension, suspension height adjust (CXY only), check AMT.
- **Indicator lamps:** High beam, fog lamps, exhaust brake, turn signals, cruise control, AMT shift mode selection.
- Gear selection display.
- Multi information display. Shows instantaneous, average and idling fuel consumption, time/day/date, voltmeter, and vehicle systems status.

### OPTIONS AND GENUINE ACCESSORIES

Include the following (extra cost, request a brochure and further details from your Isuzu dealer):

- Isuzu satellite navigation - integrates with multimedia unit.
- Up to three audio/visual reversing cameras - integrates with multimedia unit.
- Airbag compatible bullbar.
- Additional fuel tank.
- Air deflector.

## ISUZU CARE

Isuzu Care gives truck owners access to products and services including Roadside Assist, Service Agreements, Extended Care, Extended Isuzu Assist and the Isuzu Care Centre. Call 1800 035 640.

### WEIGHTS (kg)

Models	Ratings*		Loading Limit* (at ground)		Cab Chassis Mass #		
	GVM	GCM	Front	Rear	Front	Rear	Total
CXZ 415 Premium	24,000	54,000	6,600	21,000	4,465	3,530	7,995
CXY 415 Short Premium	24,000	54,000	6,600	20,865	4,340	3,340	7,680

\* Vehicle ratings and front/rear weight limits are subject to government regulatory requirements and weight distribution analysis. Consult your Isuzu dealer to select the correct vehicle for your specific application. # Cab chassis only as supplied and including 10 litres of fuel.

### DIMENSIONS (mm)

Models	WB	OAL	FOH	ROH	EA	CE	RT	ORT	CH	Turn Circle (m)			KERB TO KERB
										FFA (unladen)	RFA (unladen)	RFH (unladen)	
CXZ 415	4,300	7,680	1,400	1,980	3,085	5,516	1,850	2,440	2,970	915	1,095	1,140	16.1
CXY 415 Short	3,885	7,285	1,400	2,000	2,670	5,121	1,850	2,440	2,940	915	1,035	1,050	14.6

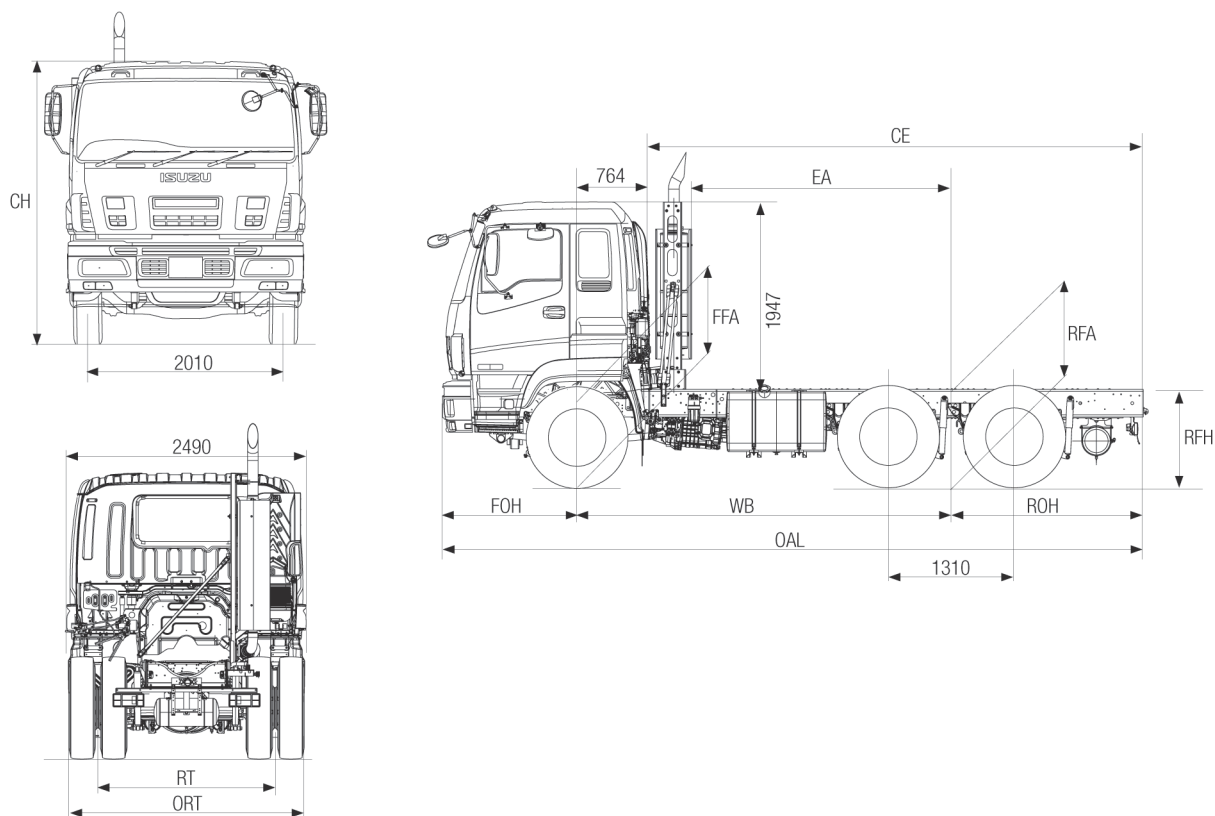

### PERFORMANCE (calculated - typical paved road)

		Geared Speed* (top gear at peak power engine RPM)	Low Speed Gradeability (lowest forward gear assuming no wheel slip)	Engine Speed (top gear at 100km/h)
CXZ/ CXY 415	At 54,000kg GCM	110 km/h @ 1,800 RPM	29%	1,635 RPM

\* Maximum speed achievable depends on vehicle frontal area as well as other factors. Consult your Isuzu dealer for more detailed information. Vehicle is speed limited to 100km/h.

### ISUZU WARRANTIES

STANDARD <sup>1</sup>	
New Vehicle	3 years • 500,000km • 6,500 hours
Cab Perforation Corrosion	3 years • unlimited km's
Engine <sup>2</sup>	5 years • 750,000 km • 10,000 hrs
Isuzu Assist: 24 hour roadside assistance (3 years, unlimited km's)*	

### ORDER CODES

Model	Code
CXZ 415 Premium	CH-CXZAC-D11 (X04)
CXY 415 Short Premium Highway	CH-CXYBC-J11 (X04)

<sup>1</sup> Subject to the conditions outlined in the IAL New Vehicle Warranty, the Isuzu CXZ and CXY models carry a standard factory warranty which covers the owner: (i) for the entire vehicle, for the first 36 months or 500,000 km or 6,500 hrs (whichever comes first), (ii) against cab perforation corrosion, for 36 months and unlimited kilometres. <sup>2</sup> Engine Warranty in the 4th and 5th year is limited to cylinder block, cylinder head and crankshaft. \*Valid for three years from the date of new vehicle purchases. All Isuzu warranties are subject to mandatory prescribed terms under Australian Consumer law including customer guarantees. For more details visit the Isuzu website which explains Isuzu warranties in more detail, or alternatively contact your local dealer. All warranties commence from date of delivery.

ISUZU AUSTRALIA LIMITED ABN 97 006 962 572 ("IAL"). The information in this spec sheet was correct at time of printing, but all measurements, specifications and equipment are subject to change without notice. Some equipment may have been changed and/or is available at extra cost. IAL may make changes at any time without notice, in prices, colours, materials, equipment and models. IAL makes all reasonable attempts to ensure the availability of all vehicles and equipment. The information in this spec sheet is general in nature. Your Isuzu dealer can confirm all measurements, specifications and vehicle / equipment availability upon request. To the extent permitted by the law, IAL is not liable to any person as result of reliance on the content of this spec sheet.

May 2015, ARK0822

We  
share  
the  
load.

**ISUZU**  
RELIABILITY IS EVERYTHING