

1400

FVZ 1400 MEDIUM/AUTO

GVM: 22,500kg
GCM: 31,750kg
WHEELBASE: 4,360mm

ISUZU 6SA1-T ENGINE PERFORMANCE

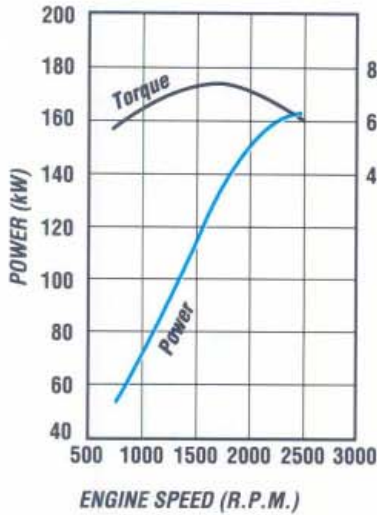

- Type: 6 cylinder, turbocharged, overhead camshaft diesel, four stroke, direct injection.
- Bore x Stroke 115 x 135 mm
- Displacement 8413 cc
- Compression Ratio 16.5:1
- Output-Power 163 kW @ 2550 rpm (DIN Nett)
- Torque 735 Nm @ 1700 rpm (DIN Nett)

DIMENSIONS AND WEIGHTS

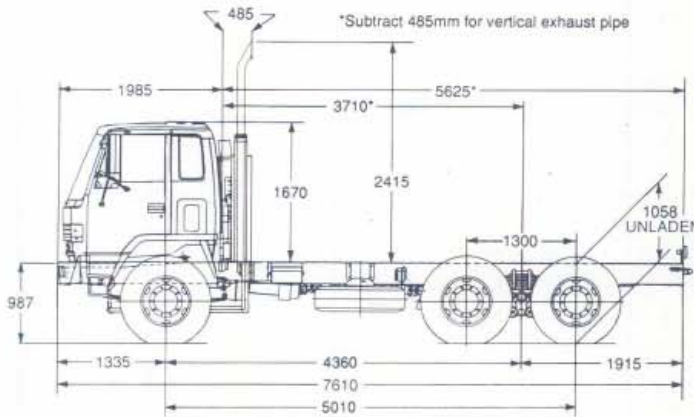

| | |
|--------------------------------|-----------|
| *ESTIMATED KERB MASS (kg) | |
| FRONT | 3130 3050 |
| REAR | 3620 3680 |
| TOTAL | 6750 6730 |
| FRAME WIDTH (mm) | 850 |
| TURNING CIRCLE (m) | |
| Kerb to Kerb | 16.6 |
| BODY LENGTH (mm) | 5486 |
| Subject to weight distribution | |

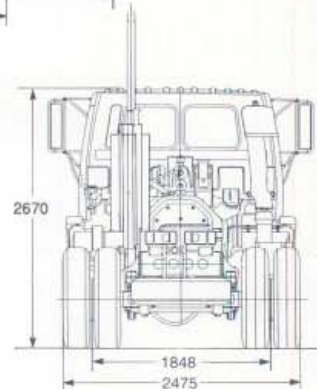

*Chassis and cab with oil, water and fuel tank containing 10 litres of fuel.

ISUZU-GENERAL MOTORS AUSTRALIA LTD A.C.N. 006 962 572

12/30 WARRANTY. Every Isuzu Truck is covered by the I-GM new vehicle warranty which covers your vehicle for the first 12 months or 50,000 kilometres.

PLEASE NOTE: as the policy of Isuzu-General Motors Australia Limited is one of continual product improvement, all specifications and equipment are subject to change without notice. Body illustrated are not standard. No I-GM dealer or other person is authorised or permitted to give or make any statement, assertion or undertaking in relation to the quality performance characteristics descriptions or fitness for any purpose of any I-GM product or in connection with the supply of any I-GM product which is at variance with any written statement assertion or undertaking on any of these subjects given or made by Isuzu-General Motors Australia Limited in its published sales literature, and the company excepts no liability for any such unauthorised action. Isuzu-General Motors Australia Limited has franchised dealers in many parts of Australia. For the sale of service parts and the provision of service to owners of I-GM products. Every endeavour is made to ensure that such dealers carry adequate stocks of service parts, and are equipped to provide satisfactory service, but makes no promise, other than that contained in the New Vehicle Warranty given by Isuzu-General Motors Australia Limited, that such parts or service facilities will be available, or available at any specific location or any particular time.





1400

FVZ 1400 MEDIUM/AUTO (ALLISON MT653)

**ORDERING CODE:
8FU02-751**

ENGINE - ISUZU 6SA1-T

Lubrication:

- Pressure feed lubrication with full flow paper element and partial flow sub filter. Plate type oil cooler in water jacket. Oil capacity 16.6 litres including filter.

Cooling System:

- Six blade plastic cooling fan, size 520 mm diameter with thermatic fan clutch.
- Horton 7 blade air assisted (Auto only).
- Tube and corrugated fin pressure type radiator with bell mouth fan shroud. Size (mm) 682 h x 559 w x 80 t. Frontal area 0.393 m².
- Coolant capacity 28.2 litres.

FUEL SYSTEM

- Two stage paper element air cleaner, Donaldson 13" with vertical air intake stack and rain head.
- In line plunger, Bosch 'AD' type fuel injection pump with mechanical all speed governor.
- In line paper filter, see through water separator with drain cock.
- Fuel tank capacity 200 litres.
- Vertical exhaust muffler, mounted on independent gantry with heat shield.

CLUTCH

- Hydraulic control dry single plate with coil type cushioning springs. 380 mm diameter.
- Air Servo assistance.
- Asbestos free lining material. Total area (both sides) 1362 cm².

TRANSMISSION - Fuller Road Ranger RT7608LL

- Ten speed direct drive, range change, oil capacity 9.2 litres.
- Gear Ratios:1

| | | | |
|----------------|-------|--------------------|-------|
| Low Low | 18.81 | 6th | 1.83 |
| Low | 12.31 | 7th | 1.36 |
| 1st | 8.24 | 8th | 1.00 |
| 2nd | 6.07 | Reverse H | 3.52 |
| 3rd | 4.51 | Reverse L | 11.87 |
| 4th | 3.32 | Reverse L.L | 17.87 |
| 5th | 2.48 | | |

- Maximum geared speed 99.6 km/h.
- One piece propeller shaft, 114.3 mm diameter Length 745 mm.
- Inter axle propeller shaft, 90 mm diameter Length 635 mm.
- Allison MT653 5 speed Direct Auto (Optional).

REAR AXLE - (E)DS451P CAPACITY 18,500kg

- Banjo type, fully floating, single reduction.
- Tandem drive, with inter axle diff lock. Ratio 4.875:1
- Spiral bevel type ring gear, 420 mm diameter Oil capacity Front 18 litres Rear 17 litres

REAR SUSPENSION

- Isuzu 6 rod, type with semi-elliptical alloy steel multi-leaf springs.
- Size: length - width x thickness, No. leaves: 1300 - 80 x 20 mm, 10 leaves

FRONT AXLE - F063 CAPACITY - 6,300 kg

- Reverse Elliot I-beam type. King pin diameter 50 mm with cylindrical roller thrust bearing. Oil filled front hubs with demountable brake drums.

FRONT SUSPENSION

- Semi-elliptical, alloy steel tapered multi-leaf springs. Fully wrapped eye with greasable shackles.
- Size: length - width x thickness, No. leaves:

| |
|------------------------|
| 1470 - 80 x 12, 1 leaf |
| 80 x 13, 4 leaves |
| 80 x 14, 1 leaf |
| 80 x 16, 1 leaf |
| 80 x 18, 1 leaf |

- Stabiliser bar.
- Hydraulic, double acting, telescopic shock absorbers.

STEERING

- Fully integral power assisted recirculating ball type. Gear ratio 22.4:1. Turns lock to lock 5.4.
- Gear driven vane type oil pump, oil capacity 3.5 litres.

BRAKES

- Full air 'S', cam, dual circuit front and rear leading and trailing. Drum diameter 419 mm. Total swept area 13,370.2 cm².
- Air tank capacity 85.9 litres, with air dryer.
- Compressor bore x stroke 85 x 60 mm driven at half engine speed.
- Spring park brake acting on rear wheels with emergency release.
- Butterfly, air controlled exhaust brake system. Activation switch on wiper/washer control stalk.

CHASSIS FRAME

- Parallel rail, ladder type, channel section, cold rivetted.
- Side member dimensions 254 x 85 x 8 mm
- Frame reinforcement angle section 238 x 77 x 4.5 at back of cab.
- Material, SAPH45 mild steel.

WHEELS AND TYRES

- 8.25T x 22.5 - 10 stud disc wheels, 22 mm bolt size. 160 mm offset.
- 11R 22.5 - 16 ply radial tyres front and rear.
- Number of tyres 11 including spare.
- Winch type spare wheel carrier.

ELECTRICAL SYSTEM

- Batteries - 2 x 12 volt - 55 amp/h, negative earth.
- Alternator - 24 volt - 40 amp.
- Starter motor - 24 volt - 5.5 kW output.
- Rear stop and tail lamps and licence plate lamp with long leads for variable body mounting. Turn signal side indicator lamps for body mounting.

CAB EXTERIOR

- All steel cab, manual tilt to 45°, electro deposition primer, torsion bar counter balanced.
- Heavy duty bumper bar with 4 rectangular halogen headlamps inset.
- Combination turn signal and park lamps.
- Tinted laminated windshield, 2 speed wiper/washer with intermittent mode.
- Tinted quarter vent, side and rear glass.
- West Coast type rear view mirrors with clearance lamps.
- Corrosion resistant, non-slip cab entry steps.
- Access to fluid checks without tilting cab.
- Tool kit with 10,000 kg capacity jack.

CAB INTERIOR

- Fully trimmed cab interior with two tone cloth seat facings, formed roof lining and overhead parcel shelf with driver and passenger sun visors.
- ISRI 6000 drivers seat with mechanical suspension and lumbar support, adjustment for seat back recline, seat slide and height control.
- Outboard reclining passenger seat, folding centre seat back with lockable compartment and snack tray.
- Outboard lap/sash seat belts with emergency locking retractor, inboard lap seat belt.
- Tilt telescopic adjustable steering column, soft feel urethane steering wheel.
- Easy entry grab handles on 'A' and 'B' pillars.
- Heater demister with 4 speed fan, 4 outlets to screen, 5 fascia outlets, 5 foot outlets.
- AM/FM radio with digital clock, dash mounted.
- Park brake activation lever beside drivers seat.

INSTRUMENTATION

- Speedometer, odometer and tachometer.
- Gauges for coolant temperature, fuel level and brake air pressure.
- Dash illumination control.

INDICATOR LAMPS

- Turn signals, parking brake on, high beam on, exhaust brake engaged.

WARNING LAMPS

- With warning bulb check switch.
- Battery charge, oil filter clogged, oil pressure, low air pressure, air cleaner clogged, stop and tail lamp failure.

SWITCHES

- Left side combination switch for exhaust brake, wipers and washer.
- Right side combination switch for headlamps, turn signals and headlamp dip.
- Hazard lamp switch.
- Key operation for engine stop and start, external engine crank switch for service when cab is tilted.
- Three way switch for interior lamp activated by driver and passenger doors.
- 24 volt 2 pin accessory plug on centre fascia.
- Controls for diff lock engagement and emergency park brake release.