

ISUZU

NKR200

FLAT LOW

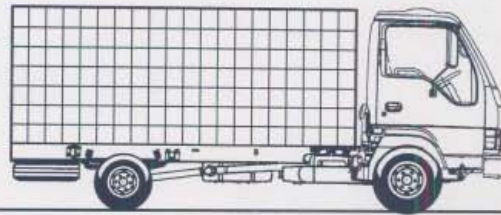

ENGINE: ISUZU 4HF1

Type: 4 cylinder, 4 stroke, overhead camshaft, direct injection diesel.
Bore x Stroke: 112 mm x 110 mm
Displacement: 4334 cc
Compression Ratio: 19.0:1
Power*: 85 kW @ 3200 RPM
Torque*: 285 Nm @ 1800 RPM

* Engine performance stated in (DIN Nett).

- Integral engine oil cooler.
- Separate full-flow and bypass engine oil filters.
- Bosch 'A' type fuel injection pump with 'RLD' all-speed governor. Quick-start glow plug cold starting aid.

COOLING SYSTEM

- Pressurised cooling system. Tube and corrugated fin type radiator with 2155 cm² frontal area. 8-blade, plastic, 430 mm diameter cooling fan with thermatic / viscous type clutch.

CLUTCH

- Hydraulically actuated, 300 mm diameter, dry single plate with 8 coil cushioning springs, single diaphragm pressure spring. Asbestos free clutch lining material. Total lining area 847 cm².

TRANSMISSION: ISUZU MXA-5R

- 5 forward speeds including overdrive, 1 reverse speed, synchromesh on all gears. P.T.O. opening left hand side.

Gear Ratios:

1st	2nd	3rd	4th	5th	Rev
4.987:1	2.870:1	1.594:1	Direct	0.728:1	4.774:1

- Maximum Theoretical Geared Speed: 112 km/h @ 3200 RPM
- Single piece propeller shaft with 82.6 mm tube diameter.

REAR AXLE: ISUZU R040

- Banjo type with full floating axle shafts.
- Axle tube size: 96 mm x 96 mm x 6 mm
- Rated capacity: 4000 kg
- Single reduction, hypoid gearing with 292 mm ring gear and 4-pinion differential. Drive ratio: 4.555:1

FRONT AXLE: ISUZU F022

- Reverse Elliot I-Beam with 2200 kg capacity.
- 30 mm diameter king-pin with ball type thrust bearing.

BRAKES

- Front and rear drum brakes with dual circuit hydraulic control, vacuum assistance and load sensing proportioning valve.
Front Drum Diameter: 300 mm.
Rear Drum Diameter: 229 mm.
- Slave cylinder / shoe types:
Front: Two leading, manual adjust.
Rear: Dual two leading, manual adjust.
- Asbestos free brake linings.
- Lining size (per wheel end):
Front: 2 x 293 mm x 75 mm x 6.0 mm
Rear: 2 x 223 mm x 75 mm x 4.9 mm
- Electro-vacuum controlled, butterfly type, 70 mm diameter Exhaust Brake.
- Drum parking brake on transmission output shaft. Control lever floor-mounted LHS of driver's seat.

AIR INTAKE SYSTEM

- Cartridge type, 150 mm diameter air filter and resonator mounted under cabin.

ELECTRICAL SYSTEM

- Batteries: 2 x 12 Volt / 65 Amp-Hour batteries in series for 24 Volt, negative ground system. Alternator: Hitachi 24 Volt / 50 Amp brushless type.
- Starting Motor: Hitachi 24 Volt / 4.0 kW reduction geared type. Rear brake, turn, reverse and marker lamp assemblies and rear registration plate lamp with additional wiring lengths. Reversing alarm.

EXHAUST SYSTEM

- Horizontal exhaust silencer and outlet pipe.

FUEL SYSTEM

- Rectangular steel fuel tank with 70 litre liquid capacity and 5 litre expansion space. Fuel / water separator with warning lamp.
- Single stage fuel filter.

STEERING

- Integral power assisted, recirculating ball type steering. Lube-for-life drag link. Gear driven, vane type oil pump.
- Gear ratio: 22.6:1
- Turns lock to lock: 4.3

SUSPENSION

FRONT

- Alloy steel, multi-leaf springs with fully wrapped eye and metalastic bushes. Nominal size: 1140 mm x 60 mm
- Hydraulic, double acting, telescopic shock absorbers.
- Stabiliser bar.

REAR

- Alloy steel, multileaf, two-stage springs. Fully wrapped main spring eyes with metalastic bushes. Nominal spring lengths:
Main spring: 1200 mm x 70 mm
Auxiliary spring: 900 mm x 70 mm
- Hydraulic, double acting, telescopic shock absorbers.

WHEELS AND TYRES

WHEELS

- Front: 5.50F x 16 JIS 6 stud disc wheels.
- Rear: 5.00J x 14 JIS 6 stud disc wheels.

TYRES

- Front: 7.00R16LT 8 P.R. Yokohama RY 215
- Rear: 175R14LT 8 P.R. Yokohama Y 356
- Total of 8 wheels and tyres supplied including 2 spare tyres (one front, one rear).

CHASSIS FRAME:

- [section rails with cold rivetted cross members forming ladder type frame.
- Rail dimensions:
Web: 170 mm x 4.5 mm
Flanges: 50 mm x 4.5 mm
- Frame width at chassis end: 800 mm

ISUZU-GENERAL MOTORS AUSTRALIA LTD A.C.N. 006 962 WARRANTY: Subject to the conditions of the I-GM New Vehicle Warranty, every Isuzu N Series Truck carries a warranty which covers your vehicle for the first 24 months or 50,000 km (whichever comes first). A 30 months or 100,000 kms (whichever comes first), power train warranty runs concurrently with the new vehicle warranty. PLEASE NOTE: as the policy of I-GM is one of continual product improvement, all specifications and equipment are subject to change without notice. Any body illustrated is not standard equipment. No I-GM dealer or other person is authorised or permitted to give or make any statement, assertion or undertaking in relation to the quality, performance, characteristics, descriptions or fitness for any purpose of any I-GM product or in connection with the supply of any I-GM product which is at variance with any written statement, assertion or undertaking on any of these subjects given or made by I-GM in its published sales literature, and the company accepts no liability for any such unauthorised action. I-GM has franchised dealers in many parts of Australia, for the sale of service, parts and the provision of service to the owners of I-GM products. Every endeavour is made to ensure that such dealers carry adequate stocks of service parts and are equipped to provide satisfactory service, but makes no promise, other than that contained in the I-GM new vehicle warranty, that such parts or service facilities will be available or available at any specific location or at any particular time. A word about this specification sheet: We have tried to make it as comprehensive and factual as possible. However, since the time of printing some of the information you will find here may have been updated. Also, some of the equipment shown or described through this specification sheet may have been changed and/or is available at extra cost. And the right is reserved to make changes at any time without notice, in prices, colours, materials, equipment and models. Your I-GM dealer has details and before ordering, you should ask him/her to bring you up to date.

CABIN EXTERIOR

- All steel cabin with manual tilting to 45°.
- Extended front wheel arch spray suppression guards.
- 90° opening, internally reinforced doors.
- Aluminium, non-slip entry steps.
- "West Coast" type rear view mirrors. Flat mirror glass both sides with additional, independently adjustable convex "spot" mirror on passenger side. Access to fluid check points without tilting cab.
- Tinted and laminated windshield.
- 2-speed windshield wiper system. Windshield washer system with triple washer jets on each wiper arm. 4 rectangular, semi-sealed type headlamps.

CABIN INTERIOR

- Entry assist handles on 'A' pillars.
- Passenger side assist grip.
- Driver's bucket seat with reclining back and fore-aft adjustment. 2-person passenger bench seat with folding seat back. Seat cushion tilts for access to engine. Fire resistant cloth seat facings.
- 3-point, lap-sash seatbelts with emergency locking belt retractors in outboard seating positions. 2-point lap seatbelt in centre seating position. Driver and passenger fold-down sun visors.
- Interior rear-vision mirror.
- Full interior panel trim with padded roof lining and vinyl floor mats. Windscreen header storage shelf.
- "Glove" compartment with door.
- "Soft feel" urethane steering wheel.
- Heater / Demister with 4-speed fan and windscreen, face and floor outlets. Optional fully integrated air conditioning. Fore-aft adjustable roof vent.
- AM / FM Stereo Radio / Cassette with integrated digital clock. Centre fascia pull-out drinks holder.
- Easy access fuse panel (behind glove compartment door).
- Windshield washer reservoir under glove compartment.
- Centre fascia and driver's door ashtrays.
- Interior lamp with On / Door / Off switch.

CONTROLS

- Key-operated engine start / stop and steering lock. Engine fast-idle vernier. Left Side Combination Stalk: Windshield wipers and washer.
- Right Side Combination Stalk: Turn signals; position, main and high beam lamps. Hazard flash switch.
- Additional interior lamp switch on instrument panel adjacent to driver's door.

INSTRUMENTATION

- Gauges: Electronically driven speedometer and tachometer. Digital odometer with integrated, dual tripmeter. Engine coolant temperature and fuel level.
- Warning Lamps: Low battery charge, brake failure, low fuel level, glow plug, water separator. Indicator Lamps: Turn signals, parking brake, high beam.

TOOLS

- 2 chassis frame mounted spare wheel and tyre winches. Wheel changing tools including 4000 kg capacity hydraulic jack. Hand tools in kit bag.

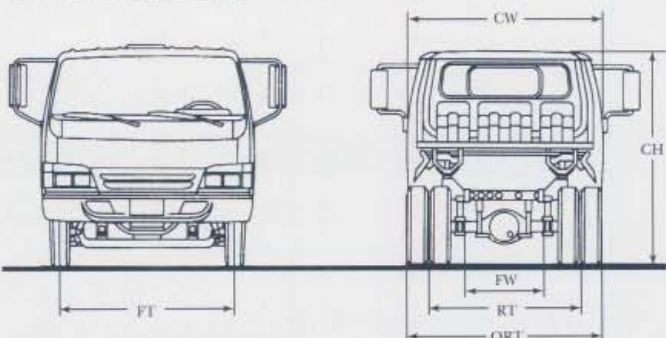

WARRANTY

- A warranty of 24 months / 50,000 km (whichever occurs first) applies to the cab-chassis vehicle. A concurrent warranty of 36 months / 100,000 km (whichever occurs first) applies to powertrain components. A concurrent warranty of 36 months (unlimited distance) applies to cabin corrosion perforation.

MODEL, CODES, RATINGS

MODEL	GVM	GCM	ORDERING CODE
NKR200 Flat Low	4200kg	4200kg	8NK52-121

KERB MASS* (kg)

	Front	Rear	Total
NKR200 Flat Low	1,350	480	1,830

* Cab-chassis, all fluids and lubricants, 10 litres fuel, spare wheel, tyre, winch and tools.

DIMENSIONS (mm)

WB Wheelbase	2490
OAL Overall Length	4620
CW Cabin Width	1695
CH Cabin Height	2140
CA Cabin To Axle (Effective)	2005
FO Front Overhang	1015
RO Rear Overhang	1115
FW Frame Width	800
FFH Front Frame Height	650
RFH Rear Frame Height	710
FT Front Track (Mean)	1400
RT Rear Track (Mean)	1290
ORT Outside Rear Track	1675
Turning Circle (Kerb to Kerb)	11.0 M

Dimensions are estimates for vehicle laden to GVMR. For other dimensions refer to body builder's diagram.

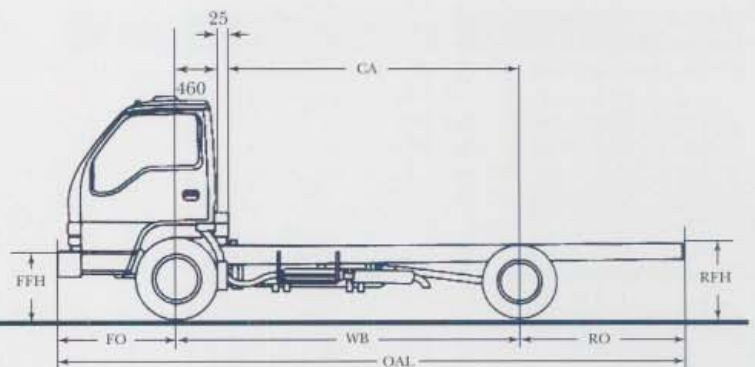

Correct as at January 1999

NKR200

FLAT LOW

ISUZU

RELIABILITY IS EVERYTHING