

ISUZU

GIGA 425 EXY

GIGAMAX 425 EXY



ISUZU
RELIABILITY IS EVERYTHING

AT A GLANCE

GVM	24,000 kg
GCM	50,000 kg (GIGA 425) 68,000 kg (GIGAMAX 425)
Engine Type	Isuzu SiTEC 425
Displacement	15.7 L
Power	316 kW @ 1,800 rpm
Torque	2,059 Nm @ 1,100 rpm
Wheelbase	3,885 mm

GIGA 425 EXY

GIGAMAX 425 EXY

DRIVELINE & CHASSIS SPECIFICATIONS

ENGINE: ISUZU SiTEC 425

Isuzu 6WG1-TC 6 cylinder, 24 valve, in line, overhead camshaft, direct injection, 4-stroke, diesel. Turbocharged and air-to-air intercooled. Cooled exhaust gas recirculation system. Electronic governor with integral speed limiter and cruise control with resume function. Bore & Stroke: 147 x 154 mm Displacement: 15,681 cc Compression Ratio: 15.5:1 Power: 316 kW @ 1,800 rpm (ISO 1585 NET) Torque: 2,059 Nm @ 1,100 rpm (ISO 1585 NET) Emission Standard: ADR 80/00 (Euro III)

AIR INTAKE SYSTEM

- Donaldson dry element, 15" two stage air filter. Vertical air intake stack with slim profile side intake.

EXHAUST SYSTEM

- Vertical muffler with bright perforated heat shield on right side.
- Air controlled, butterfly type exhaust brake (up to 350 hp retardation at 2,200 rpm). Exhaust brake idle cut-out switch.

FUEL SYSTEM

- Denso common rail fuel injection system. In-line fuel filter and water sedimentor.
- Fuel tank: 1 x 450 L Hilton aluminium cylindrical (LHS) with two full length tank-mounted steps.

LUBRICATION SYSTEM

- Pressure feed lubrication system. Oil capacity 31.0 L (including filters).

CLUTCH

EATON FULLER (SPICER) 15.5"

- Twin plate clutch (6 pads) with clutch brake.
- Asbestos free lining material.
- Pneumatic clutch release assistance.

TRANSMISSION

- Eaton Fuller RTLO 16913A 13 speed (EXY Standard cab).
- Eaton Fuller RTLO 16918B 18 speed (EXY Custom cab).
- Eaton Fuller RTLO 18918B 18 speed (GIGAMAX Custom).
- Overdrive, constant mesh transmission with integral oil pump and oil cooler.

- Gear ratios: 13 speed transmission

Forward: (:1)

Lo: 12.31	1st: 8.64	2nd: 6.11	3rd: 4.43
4th: 3.23	5th L: 2.29	5th H: 1.95	6th L: 1.62
6th H: 1.38	7th L: 1.17	7th H: 1.00	8th L: 0.86
8th H: 0.73			

Reverse: (:1)

Hi Rev H: 2.99 Hi Rev L: 3.50 Lo Reverse: 13.22

- Gear ratios: 18 speed transmission

Forward: (:1)

Lo L: 14.40	Lo H: 12.29	1st L: 8.56	1st H: 7.30
2nd L: 6.05	2nd H: 5.16	3rd L: 4.38	3rd H: 3.74
4th L: 3.20	4th H: 2.73	5th L: 2.29	5th H: 1.95
6th L: 1.62	6th H: 1.38	7th L: 1.17	7th H: 1.00
8th L: 0.86	8th H: 0.73		

Reverse: (:1)

Hi Rev H: 2.99 Hi Rev L: 3.50 Lo Reverse: 13.22

- Spicer propeller shaft. Spicer Inter-axle shaft.

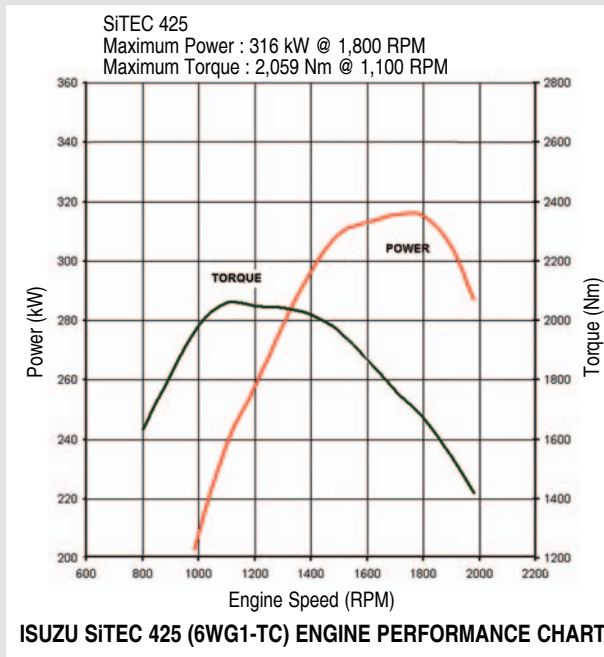

AXLES

FRONT: MERITOR FG941

- 6,600 kg capacity.
- 3.5" drop centres and oil bath hubs.
- 42° wheel cut angle.

REAR

GIGA 425 EXY

MERITOR RT40-145GP

- 18,100 kg capacity tandem axle set with integral oil pump.
- Final drive ratio 4.111:1 (Standard; others available)

GIGAMAX 425 EXY

MERITOR RT46-160GP

- 21,000 kg capacity tandem axle set with integral oil pump.
- Final drive ratio 4.30:1 (Standard; others available)
- Inter-axle differential lock. Driver controlled differential cross-locks on both axles.
- Banjo type, fully floating, single reduction

SUSPENSION

FRONT

- Long span alloy steel tapered leaf springs.
- Nominal size: 1,800 x 80 mm
- Total spring capacity (at ground): 6,740 kg
- Stabiliser bar and shock absorbers.

REAR

- EXY - Hendrickson HAS 400 air bag rear suspension. Total spring capacity (at ground): 18,140 kg
- GIGAMAX - Hendrickson HAS 461 Heavy Duty air bag rear suspension. Total spring capacity (at ground): 20,865 kg.
- Dual height control valves.
- Transverse torque rod and shock absorbers.
- In-cab height raise/lower and dump switch for hitching and unhitching trailers (external switch also supplied).

BRAKES

MERITOR "Q PLUS"

- Full air, S-cam dual circuit brake system. Automatic slack adjusters. Asbestos free lining material.

- Front drum diameter: 419 mm
- Rear drum diameter: 419 mm
- Swept area: 12,716 cm²
- Air Compressor: 519 L/min at 700 kPa at 2,000 engine rpm.
- Total capacity 118.4 L, Air dryer (heavy duty desiccant type).
- Spring parking brake acting on all rear wheels.
- Trailer brake connection at rear of cab.

STEERING

- Power assisted recirculating ball steering.
- Steering ratio: 22.4:1

WHEELS AND TYRES

- 8.25 x 22.5-10 stud ISO standard steel disc rims. 335 mm PCD.
- 295/80R22.5 152/148M Michelin XZE2 steer tyres.
Rating: 3,550 kg per tyre
- 11R22.5 148/145 L Michelin XDE2 drive tyres.
Rating: 2,900 kg per tyre (dual configuration)
- Spare rim only supplied on chassis (no spare tyre).

AXLE LOAD SUMMARY

GIGA 425 EXY	FRONT	REAR
Axle Capacity (kg):	6,600	18,100
Spring Capacity (kg):	6,740	18,140
Tyre Capacity (kg):	7,100	23,200
Legal Limit (kg):	6,000	17,000
Limit (kg):	6,000	17,000
GIGAMAX 425 EXY	FRONT	REAR
Axle Capacity (kg):	6,600	21,000
Spring Capacity (kg):	6,740	20,865
Tyre Capacity (kg):	7,100	23,200
Legal Limit (kg):	6,000	17,000
Limit (kg):	6,000	17,000

Note: Vehicle loading limit is determined by the combination of axle loading limit, GVM and GCM limit, and government regulatory requirements. Consult your Isuzu dealer to select the correct vehicle for your specific application.

CHASSIS FRAME

- Ladder type, parallel rail, tapered, C-section type. HT540 steel.
- Frame dimensions
Side rail (mm): 285 x 85 x 8
Rear frame width (mm): 850
- Turntable angles supplied.

ELECTRICAL SYSTEM

- 24 Volt electrical system.
- 24 Volt, 60 Amp alternator(1.5 kW).
- 24 Volt, 7.4 kW starter motor.
- 2 x 145G51(754CCA) batteries connected in series.
- 24 Volt electrical connectors at rear of cab.

GENERAL OPTIONS (available at extra cost)

- Additional Hilton fuel tank (Increases total capacity to 900 L).
- Alternative axle ratios on request from your Isuzu Dealer.

DEALER-FITTED ACCESSORIES INCLUDE:

- 10-Disc CD stacker (standard on Custom Cab).
- Voltage reducer (24 Volt-12 Volt) for 12 Volt trailer electrics.
- Roof Mounted Air Deflector. Designed by Isuzu for use with tall body designs, reducing fuel consumption.
- Full aerodynamic fairing, designed to integrate with rear of cab and roof-mounted air deflector. Fills the space between rear of cab and front of body or trailer, reducing aerodynamic drag and minimising fuel consumption.
- Alcoa forged aluminium alloy wheels, reducing tare mass by 135 kg and improving appearance.
- Anti-Lock Braking Systems (ABS). Meritor axles and brakes are compatible with WABCO and Bosch systems.
- 5th wheel assembly.
- HAS 460 suspension upgrade kit (for 50,000 kg GCM models).
- Rear wheel guards.

CABIN SPECIFICATIONS AND APPOINTMENTS

CAB EXTERIOR

- All steel cab with welded ribs and side door impact beams. Standard colour: Arc White.
- Hydraulic/electric cabin tilt to 48°. Air suspended cab with four electronically controlled pneumatic mounts, shock absorbers and torque tube.
- Large bumper bar / air dam with enclosed step holes and footplate.
- Halogen headlights in bumper with hinges for easy cleaning. 'Hella' fog lights integrated into air dam.
- Three arm windscreen wipers with triple washer jets mounted on washer arms.
- Main external rear view mirrors with integrated convex 'spotter' mirror on both sides. Electric remote adjustment and heating elements in all four external mirrors.
- Integrated front corner vanes for improved airflow.
- Fully enclosed alloy, non-slip cab entry steps. Large grab handle mounted adjacent to muffler.

CAB INTERIOR

- Fully trimmed cab interior with cloth seat facings, formed roof lining and overhead storage lockers. Sun visors on both sides. Fluorescent overhead interior lamp. Integrated air conditioning. Carpet on cab floor.
- 24 Volt & 12 Volt cigarette lighter/electrical accessory socket.

- Isringhausen 6800 driver's air suspended seat with integrated seat belt, pneumatic lumbar support, automatic weight adjustment and dump button for ease of entry and exit. Height, rake and backrest recline adjustment. Outboard non-suspended reclining co-driver's seat with matching Isringhausen trim.
- Easy entry grab handles on 'A' and 'B' pillars.
- Large centre console with integrated heat/cool box and twin cup holders.
- Electric windows. Central locking with remote keyless entry.
- Eurovox radio CD player with digital anti skip memory and 4 speakers (13 speed model only).
- ADR compliant sleeper mattress: approx. 2,200 x 600 x 100 mm
- Air conditioning vent in sleeper compartment.
- Centre curtain for privacy when sleeping.
- Secure storage trunk with external access on LHS.

CUSTOM CAB FEATURES (18 spd models only)

- Custom badges. Gold colour Isuzu badge.
- Complete wrap-around window curtains - covers all windows.
- Wood grain appearance to instrument panel.
- Leather wrap steering wheel.
- Eurovox radio cassette player with premium rear speakers. 10 disc CD stacker with digital anti skip.

GIGA 425 EXY

13 spd: 8EX22-311 18 spd custom: 8EX22-417

GIGAMAX 425 EXY

18 spd custom: 8EX22-447

PERFORMANCE (Calculated)

	GIGA 425 EXY	GIGAMAX 425 EXY
Max Geared speed:	130* km/h @ 2,000 rpm	125* km/h @ 2,000 rpm
Gradeability (lowest gear):	40% (13 spd), 47% (18 spd) at 45,500 kg GCM	49% at 45,500 kg GCM
Gradeability (top gear at 100 km/h):	0.8% (semi trailer at 45,500 kg GCM)	0.8% (semi trailer at 45,500 kg GCM)
Engine speed (top gear at 100km/h):	1,535 rpm	1,605 rpm

Performance figures quoted are representative only and based on typical dimensions, body styles and weights. Please consult your Isuzu dealer for an estimation based on your specific application. *Road speed limited to 100 km/h

MODEL RATINGS AND DIMENSIONS

MODELS	RATINGS(kg)		TARE MASS#(kg)			DIMENSIONS (mm)							TURNING CIRCLE	
	GVM	GCM	TOTAL	FRONT	REAR	WB	OAL	FOH	ROH	CA	CE	FFH UNLADEN	RFH UNLADEN	KERB TO KERB
GIGA 425 EXY	24,000	50,000	7,300	4,275	3,025	3,885	6,920	1,400	1,635	3,165	4,800	900	1,040	14.9m
GIGAMAX 425 EXY	24,000	68,000	7,510	4,250	3,260	3,885	6,920	1,400	1,635	3,165	4,800	900	1,040	14.9m

#Estimated mass of cab/chassis with oil, water and fuel tank containing 20 litres of fuel and excluding spare rim (40kg) and tools (30kg). Option Masses: • Roof Mounted Air Deflector add 35 kg • Side fairings add 60 kg • Additional fuel tank add 90 kg

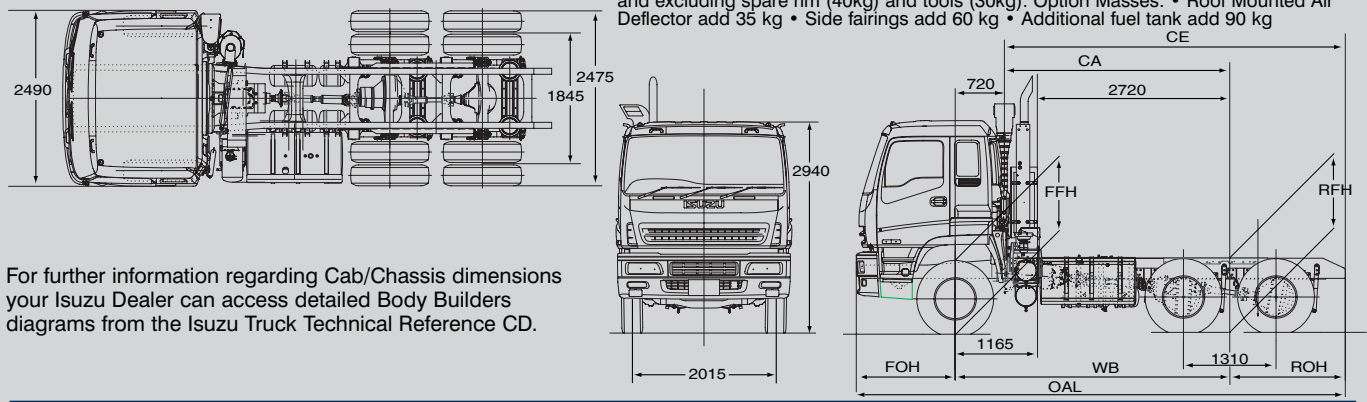

For further information regarding Cab/Chassis dimensions your Isuzu Dealer can access detailed Body Builders diagrams from the Isuzu Truck Technical Reference CD.

ISUZU NEW TRUCK WARRANTIES

STANDARD TRUCKPOWER WARRANTY*

NEW VEHICLE	3 years	500,000 km
ENGINE COMPONENTS*	5 years	750,000 km
CAB CORROSION	3 years	unlimited

* Subject to the conditions outlined of the I-GM New Vehicle Warranty, every Isuzu Giga Series Truck carries a warranty which covers your complete vehicle for the first 36 months or 500,000 km (whichever comes first). Normal exclusions apply: e.g. tyres and batteries (refer to your Isuzu Dealer for details).

A 60 month or 750,000 km (whichever comes first) major engine components warranty runs concurrently with the New Vehicle Warranty for Giga Series models. A 36 month unlimited km cab perforation corrosion warranty runs on all models.

* Engine components are as follows: Cylinder block, cylinder head and crankshaft.

Why have Isuzu Trucks been Australia's No. 1 choice since 1989? *

- Widest range of models to suit most applications
- Premium componentry and Isuzu diesel engines
- Network of over 40 specialist Isuzu Dealerships and branches
- Sales, services and parts support
- Predictable operating costs through Dealer ISIS program
- Factory and range of extended warranties available
- High resale values
- Leading reputation for reliability

www.isuzu.com.au

* Source Truck Tracker 2003

YOUR ISUZU DEALER

ISUZU-GENERAL MOTORS AUSTRALIA LTD A.C.N. 006 962 572. PLEASE NOTE: as the policy of I-GM is one of continual product improvement, all specifications and equipment are subject to change without notice. No I-GM dealer or other person is authorised or permitted to give or make any statement, assertion or undertaking in relation to the quality, performance, characteristics, descriptions or fitness for any purpose of any I-GM product or in connection with the supply of any I-GM product which is at variance with any written statement, assertion or undertaking on any of these subjects given or made by I-GM in its published sales literature, and the company accepts no liability for any such unauthorised action. I-GM has franchised dealers in many parts of Australia, for the sale of service, parts and the provision of service to the owners of I-GM products. Every endeavour is made to ensure that such dealers carry adequate stocks of service parts and are equipped to provide satisfactory service, but makes no promise, other than that contained in the I-GM new vehicle warranty, that such parts or service facilities will be available or available at any specific location or at any particular time. A word about this specification sheet. We have tried to make it as comprehensive and factual as possible. However, since the time of printing some of the information you will find here may have been updated. Also, some of the equipment shown or described through this specification sheet may have been changed and/or is available at extra cost. And the right is reserved to make changes at any time without notice, in prices, colours, materials, equipment and models. Your I-GM dealer has details and before ordering, you should ask him/her to bring you up to date.

OCTOBER 2004. ARK/IGM 0149

ISUZU

RELIABILITY IS EVERYTHING