

# NPS 300 4X4

GVM: 6000kg  
GCM: 8000kg  
WHEELBASE: 3400mm

# 300

## ISUZU 4HF1 ENGINE PERFORMANCE

- Type: 4 cylinder, OHC diesel, four stroke, direct injection
- Bore x stroke: 112 x 110 mm
- Displacement: 4334 cc
- Compression Ratio: 18.5:1
- Output -  
Power:  
85kW @ 3200 rpm (DIN Nett)  
Torque:  
289 Nm @ 1900 rpm (DIN Nett)

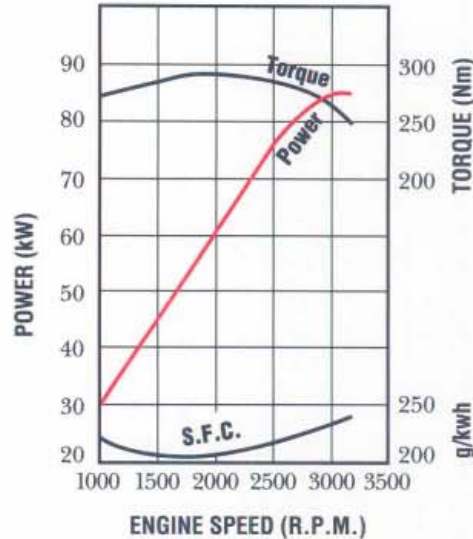

## DIMENSIONS AND WEIGHTS

ESTIMATED KERB MASS (kg)	
FRONT	1740
REAR	880
TOTAL	2620
FRAME WIDTH (mm)	750
TURNING CIRCLE (m)	
Kerb to Kerb	14.0
BODY LENGTH (mm)	4570
Subject to weight distribution	
RECOMMENDED MAX. BODY WIDTH (mm)	2300

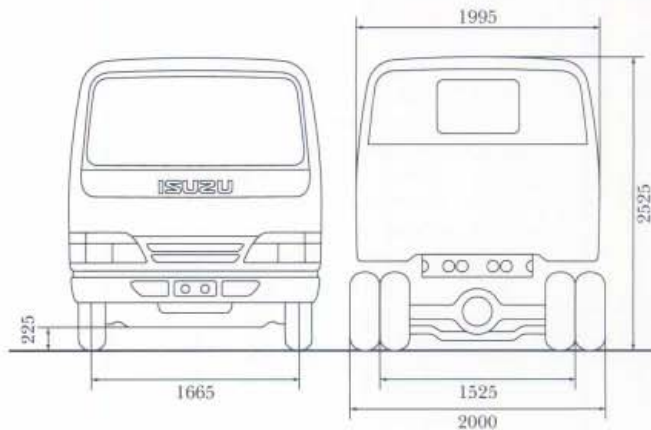

Chassis and cab with oil, water and fuel tank containing 10 litres of fuel.

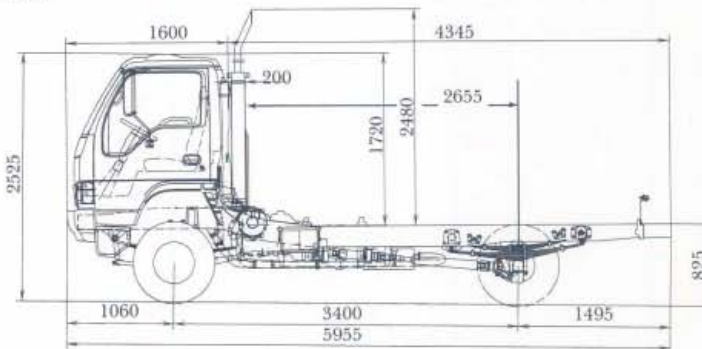

ISUZU-GENERAL MOTORS AUSTRALIA LTD A.C.N. 006 962 572.  
12/20 WARRANTY. Every Isuzu Truck is covered by the IGM new vehicle warranty which covers your vehicle for the first 12 months or 20,000 kilometres.  
PLEASE NOTE: as the policy of Isuzu-General Motors Australia Limited is one of continual product improvement, all specifications and equipment are subject to change without notice. Body illustrated is not standard. No IGM dealer or other person is authorised or permitted to give or make any statement, assertion or undertaking in relation to the quality performance characteristics descriptions or fitness for any purpose of any IGM product or in connection with the supply of any IGM product which is at variance with any written statement, assertion or undertaking on any of these subjects given or made by Isuzu-General Motors Australia Limited in its published sales literature, and the company accepts no liability for any such unauthorised action. Isuzu-General Motors Australia Limited has franchised dealers in many parts of Australia, for the sale of service parts and the provision of service to owners of IGM products. Every endeavour is made to ensure that such dealers carry adequate stocks of service parts, and are equipped to provide satisfactory service, but makes no promise, other than that contained in the New Vehicle Warranty given by Isuzu-General Motors Australia Limited, that such parts or service facilities will be available, or available at any specific location or any particular time.

## ENGINE - ISUZU 4HF1

### Lubrication:

- Pressure feed lubrication with full flow paper element and partial flow sub filter. Plate type oil cooler in water jacket.

### Cooling System:

- Eight blade plastic cooling fan, size 430 mm diameter, with thermatic fan clutch.
- Tube and corrugated fin pressure type radiator. Size (mm) 547 h x 471 w x 54 t.
- Frontal area 0.258 m<sup>2</sup>.

## FUEL SYSTEM

- Cartridge type paper element air cleaner with resonator mounted high up on the chassis, with vertical air intake stack mounted behind cab.
- In line plunger, Bosch 'A' type fuel injection pump with mechanical all speed governor. In line paper filter, Fuel/water sedimentor with warning lamp.
- Fuel tank capacity 115 litres.
- Horizontal exhaust muffler with vertical exhaust stack, with anti-rust coat.

## CLUTCH

- Hydraulic control, dry single plate with diaphragm spring, asbestos free clutch plate with silent disc, 300 mm diameter. Lining area 847 cm<sup>2</sup> (each side).

## TRANSMISSION ISUZU MXA5R

- 5 speed overdrive, synchromesh with remote control short gear shift lever.
- High-low ratio lever on steering column.

### Gear ratios: 1

1st 4.987

2nd 2.870

3rd 1.594

4th 1.000

5th 0.728

Reverse 4.777

- Maximum geared speed 103 km/h.

- 2 speed transfer case.

- Ratios: 2

High 1.000

Low 1.868

- 3 piece propeller shaft, 82.6 mm diameter.

Length: Front: 665 mm

Rear: 1st section 488 mm

2nd section 993 mm

- Transfer case to front axle 82.6 mm 655 mm
- Transfer case to centre bearing 82.6 mm 501 mm
- Centre Bearing to rear axle 82.6 mm 981 mm

## REAR AXLE-CAPACITY 5000KG

- Banjo type, fully floating, single reduction.
- Ratio 6.142:1.
- Hypoid type ring gear: 292 mm diameter.
- Oil capacity: 3 litres.
- Limited slip differential.

## REAR SUSPENSION

- Semi elliptical, alloy steel, tapered multi leaf springs, with fully wrapped eye.

- Size:

length - width x thickness; no. leaves

Main:

1300 - 70 x 10 mm - 7 leaves

Auxiliary:

970 - 70 x 10 mm - 5 leaves

- Hydraulic, double acting, telescopic shock absorbers, bias mounted.

## FRONT AXLE-CAPACITY 2600KG

- Banjo type, fully floating with Birfield type steering ball joint, manual locking free wheeling hubs. Ratio 6.142:1.
- Brush guard steering protector.

## FRONT SUSPENSION

- Semi elliptical, alloy steel, tapered multi-leaf springs, with fully wrapped eye.

- Size:

length - width x thickness; no. leaves

1200 - 70 x 10 mm - 7 leaves

- Stabiliser bar.

- Hydraulic, double acting, telescopic shock absorbers, bias mounted.

## STEERING

- Fully integral power assisted recirculating ball type. Gear ratio 20.9:1. Turns lock to lock 5.0.
- Steering lock.
- Gear driven vane type oil pump, oil capacity 1.6 litres.

## BRAKES

- Hydraulic dual circuit, vacuum assisted, front two leading, rear dual two leading (auto. adj.).
- Drum width 75mm front, 100 mm rear. Diameter front and rear 320 mm. Total swept area 3516 cm<sup>2</sup>.
- Asbestos free lining material. Width 100 mm.
- Mechanical park brake, internal expanding at rear of transmission. Lever beside seat.
- Butterfly, vacuum controlled exhaust brake system. Activation switch on wiper/washer control stalk.
- Load sensing proportioning valve.

## CHASSIS FRAME

- Ladder type, channel section, cold rivetted.
- Side member dimensions 203 x 65 x 6 mm.

## WHEELS AND TYRES

- 6.00GS x 16 - 6 stud disc wheel, 20 mm bolt size.
- 7.50 R - 16 LT - 10 ply (Yokohama) tyres. (On-off road tread pattern.)
- Option: 7.50 - 16 LT - 10 ply.
- Number of tyres, 7 including spare.
- Winch type spare wheel carrier, rear mounted.

## ELECTRICAL SYSTEM

- Batteries - 2 x 12 volt - 65 amp/h, negative earth.
- Alternator - 24 volt - 25 amp.
- Starter motor - 24 volt - 4.5 kW output.
- Rear stop and tail lamps with long leads for variable body mounting.
- Back-up warning beeper and lamps.

## CAB EXTERIOR

- All steel cab, manual tilt to 45°.
- Aluminium non-slip entry steps.
- West Coast type rear view mirrors with clearance lamps.
- Access to fluid checks without tilting cab.
- Tinted, laminated windshield, bonded in position, 2 speed wiper/4 jet washer with intermittent mode.
- 4 rectangular semi-sealed beam headlamps.
- Combination turn signal and park lamps.
- Plastic wheel house liner.
- Cab roof air vent with fore and aft tilt.
- Engine access hatch in floor.

## CAB INTERIOR

- Adjustable and reclining driver's bucket seat with lumbar support, 2 place passenger bench seat, with folding back.
- Fire resistant vinyl seat material.
- Retractable lap/sash seat belts on out-board seats, lap belt on inboard seat.
- Driver and passenger sun visors, padded roof lining.
- 90° opening, internally reinforced doors, double sealed.
- Tilt telescopic adjustable steering column with soft feel urethane steering wheel.
- Easy access pull down fuse cover.
- Easy entry grab handles on 'A' pillar.
- Windshield washer tank located under glove compartment.
- Heater demister with 4 speed fan.
- AM/FM stereo radio cassette with digital clock, dash mounted.
- Tool kit with 5000 kg capacity jack.
- Windshield header shelf.
- Optional air conditioning.

## INSTRUMENTATION

- Electronically driven speedometer with odometer and trip meter.
- Tachometer, electronically driven.
- Gauges for coolant temperature and fuel level.

## INDICATOR LAMPS

- Turn signals, parking brake on, high beam on, exhaust brake engaged, 4 wheel drive engaged.

## WARNING LAMPS

- Battery charge, oil pressure, brake failure, fuel level, coolant level, glow plug and water separator.

## SWITCHES

- Left side combination switch for exhaust brake, wipers and washer. Intermittent wipe, washer activated.
- Right side combination switch for turn signals and headlamps.
- Hazard switch.
- 4 wheel drive engagement switch.
- Key operation for engine stop/start with quick cold start aid.
- Three way switch for interior lamp activated by driver and passenger doors.
- Fast engine warm-up control.
- Fast engine idle control.