

ISUZU

SPECIFICATIONS

FSR 700 | 850 Dual Control



FSR 850

AUSTRALIA'S TOP SELLING TRUCK BRAND SINCE 1989.

AT A GLANCE

| | |
|--------|----------------------|
| GVM | 12,000 / 14,000 kg* |
| GCM | 18,000* / 20,000 kg* |
| Power | 176 kW @ 2,400 rpm |
| Torque | 706 Nm @ 1,450 rpm |

* Refer to back page weights table for details

ADVANCED TECHNOLOGY

Fully integrated dual control system

Emissions: Euro V / ADR 80/03

Meets EEV emissions standard

RHS driver airbag with seatbelt pretensioner

ADR42 compliant sleeper

ECE-R93 compliant front underun protection device (FUPD)

Anti-lock Braking System (ABS)

Electric mirrors

Front stabiliser bar

Cruise control

LHS and RHS ISRI 6860 seats with integrated seatbelt



We
share
the
load.

ISUZU
RELIABILITY IS EVERYTHING

FSR Dual Control

DRIVELINE AND CHASSIS SPECIFICATIONS

ENGINE: SITEC SERIES III 235 (ISUZU 6HK1-TCN)

- Type:** 6 cylinder 24 valve SOHC
Displacement: 7,790 cc
Compression Ratio: 17.5:1
Bore x Stroke: 115 mm x 125 mm
Max power (DIN-NET): 176 kW (236 HP) @ 2,400 RPM
(JIS Gross): 182 kW (244 HP) @ 2,400 RPM
Max torque (DIN-NET): 706 Nm (521 lb.ft) @ 1,450 RPM
(JIS Gross): 731 Nm (539 lb.ft) @ 1,450 RPM
Induction system: Electronically controlled variable nozzle turbocharger with air-to-air intercooler.
Fuel injection: Direct injection high pressure common rail system.
Emission control system: Cooled EGR with exhaust Diesel Particulate Diffuser (DPD). ADR 80/03 (Euro V) compliant. EEV compliant.

TRANSMISSION

ALLISON LCT2500

- 6 speed automatic. 5th generation electronic controls with adaptive shift.
- LHS and RHS PTO openings on transmission case. Torque convertor turbine driven PTO drive gear.
- Gear ratios (:1)

| 1st | 2nd | 3rd | 4th | 5th | 6th | Rev |
|------|------|------|------|------|------|------|
| 3.51 | 1.90 | 1.44 | 1.00 | 0.74 | 0.64 | 5.09 |

AXLES

- Front:** Isuzu F050
- Reverse Elliot I-beam. 5,000 kg capacity.
- Rear:** Isuzu R090
- Full floating Banjo type. 9,000 kg capacity.
 - Drive ratio: 4.875:1

SUSPENSION

- Front:**
- Single stage alloy steel taper leaf springs.
 - Double acting hydraulic shock absorbers. Stabiliser bar.
- Rear:**
- Multi leaf main spring, multi leaf helper spring.

BRAKES

- Dual circuit air over hydraulic front and rear drum brakes.
- Dual air control valves for LHS and RHS driving positions.
- ABS.
- Front drum size: 370 x 150 mm
- Rear drum size: 370 x 150 mm
- Spring park brake.
- Air controlled exhaust brake.
- Air dryer.

STEERING

- Power assisted recirculating ball steering. LHS and RHS control positions linked by gear driven cross shaft.
- Gear ratio: 16:1 - 18.8:1
- Turns lock to lock: 4.1
- Maximum angle: 44° (inside wheel) / 34° (outside wheel)

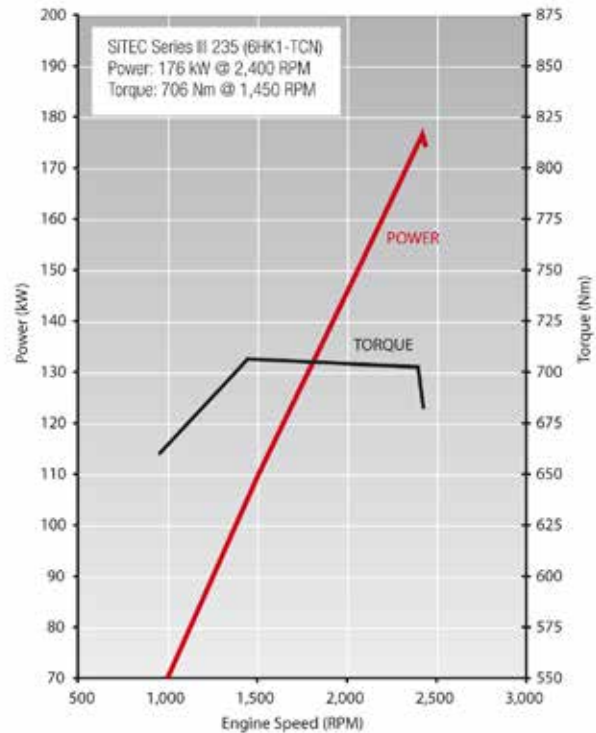

WHEELS AND TYRES

- 19.5 x 6.75 eight stud ISO standard steel wheels.
- 265/70R19.5 140/138M Michelin XZE2 Tubeless.
- Maximum tyre rating:
 - Steer axle: 5,000 kg
 - Drive axle: 9,440 kg
- Spare wheel and tyre assembly with winch type carrier.

CHASSIS FRAME

- Cold rivetted ladder frame with parallel side rails. HT540A high tensile weldable steel sidemembers.
- Frame dimensions:
 - Side rail (mm): 225 x 70 x 6.0
 - Rear frame width (mm): 840

FUEL TANK

- Frame mounted 200L steel fuel tank.
- Lockable fuel cap.

ELECTRICAL SYSTEM

- 24 volt electrical system.
- 90 amp alternator.
- 24 Volt, 4.5 kW starter motor.
- 2 x 115E41L (651 CCA) batteries connected in series.
- Underdash CAN interface unit and connector. SAE J1939 protocol. Facilitates connection to a Fleet Management System (FMS) (not supplied).

CABIN SPECIFICATIONS AND APPOINTMENTS

CAB EXTERIOR

- All steel construction. High tensile steel used for cab underframe. Manual cab tilt to 45° with torsion bar assistance.
- Liquid filled front and rear cab mounts.
- Heavy duty non slip entry steps.
- 90° opening internally reinforced front doors.
- Water spray suppression guards and front mudflaps.
- Laminated windscreen with shade band.
- Two speed windscreen wipers, with intermittent wipe mode.
- Halogen multi-reflector headlamps incorporating turn signals. Additional door mounted integrated side indicator/cornering lamps.
- Combination brake, turn, reverse and marker lamps, registration plate illumination lamps. Extended wiring harness. Reverse alarm.
- Roof-mounted clearance lamps.
- Heated and powered exterior main mirrors with flat glass and additional powered convex "spot" mirrors.
- Body coloured grille.
- FUPD underbar - complies with ECE R93.
- Body coloured steel air dam bumper with front foglamps.

CAB INTERIOR

- Isri 6860 air suspension driver's seat for LHS and RHS control positions. Pneumatic lumbar support, height, rake and automatic weight adjustment.
- 3-point lap sash seatbelts integrated with seats. RHS driver seatbelt fitted with pre-tensioner.
- ADR42 compliant sleeper.
- RHS driver airbag.
- Door and roof pillar entry assist grips.
- Full interior trim, padded roof lining and vinyl floor covering. LHS and RHS windscreen header storage shelf.
- Electrically adjustable tilt steering columns, soft feel urethane steering wheels.
- Electric windows.
- Central locking with remote keyless entry and immobiliser.
- Twin cup holders. 24V cigarette lighter.
- Front door mounted storage pockets and RHS ashtray.
- Centre console box with storage tray. Fold down storage tray behind centre seat backrest.
- Fully integrated air conditioning and heater/demister with 4-speed fan and outlets for windscreen, side windows, face and floor.
- Fluorescent type interior lamp with On/Door/Off switch.
- 2 DIN, two speaker radio/CD/DVD Digital Audio Visual Entertainment (DAVE) unit with 6.2" LCD touch screen DAB+ digital radio and fully integrated Bluetooth with voice recognition. 4GB internal storage for music files. USB/SD card and auxiliary input connection provisions.
- DIN sized compartment for storage or for CB radio installation.

DRIVER CONTROLS

- Key-operated centrally mounted engine start/stop. Engine idle speed control.
- Centrally mounted LHS or RHS driving position selection switch. Controls power window switch priority, accelerator pedal and steering column control stalks according to driver position.
- DPD regeneration.
- Electronic servo controlled push-button gear selection.
- **Left side combination stalk:** Windscreen wipers, washers and exhaust brake.
- **Right side combination stalk:** Turn signals, headlamps and cruise control.

INSTRUMENTATION

- Dual LHS and RHS instrument clusters operating in parallel. Electronically driven speedometer and tachometer. Digital odometer with integrated dual tripmeter. Engine coolant temperature, fuel level and air pressure gauges.
- **Warning lamps:** Check engine, oil pressure, ABS, SRS airbag, alternator charge, service brakes, park brake, seatbelt unfastened, low air pressure, low fuel level, cab lock.
- **Indicator lamps:** Warm up system, high beam, DPD status, exhaust brake, turn signals, cruise control, LHS driver position activated.
- Gear selection display.
- Multi-information display. Shows service interval, instantaneous and average fuel consumption, DPD bar chart, hourmeter, voltmeter, time/day/date and includes 40-120 km/h adjustable vehicle speed warning.

OPTIONS AND GENUINE ACCESSORIES

Include the following (extra cost, request a brochure and further details from your Isuzu dealer):

Digital Audio Visual Entertainment unit:

- Isuzu satellite navigation including three years of free updates.
- Supports up to four camera inputs, one camera and rear microphone input active when reversing. Reversing sensors.
- Tyre pressure monitoring system.
- Cables for full iPod / iPhone / iPad compatibility and connection to other external audio visual devices.

Other:

- Dual control pack - includes beacon and switch, 'Dual Control' warning decals.
- Airbag compatible bullbar.
- Air deflector.

ISUZU CARE

Isuzu Care gives truck owners access to products and services including Roadside Assist, Service Agreements, Extended Care, Extended Isuzu Assist and the Isuzu Care Centre. Call 1800 035 640.

WEIGHTS (kg)

| Models | Ratings* | | Loading Limit* (at ground) | | Cab Chassis Mass # | | |
|--------------------------|-------------------|---------------------|----------------------------|-------|--------------------|-------|-------|
| | GVM | GCM | Front | Rear | Front | Rear | Total |
| FSR 700/850 Dual Control | 12,000 / 14,000** | 18,000** / 20,000** | 5,000 | 9,000 | 2,575 | 1,405 | 3,980 |

* Vehicle ratings and front/rear weight limits are subject to government regulatory requirements and weight distribution analysis. Consult your Isuzu dealer to select the correct vehicle for your specific application.

** Pre-approved ratings as stated apply for general transport and distribution applications. For other applications approval from Allison is required. For example, GVM and GCM limits of 12,000kg apply for refuse application.

Cab chassis only as supplied and including 10 litres of fuel.

DIMENSIONS (mm)

Turn Circle (m)

| Models | WB | OAL | FOH | ROH | EA | CE | RT | ORT | CH | FFA (unladen) | RFA (unladen) | RFH (unladen) | KERB TO KERB |
|--------------------------|-------|-------|-------|-------|-------|-------|-------|-------|-------|---------------|---------------|---------------|--------------|
| FSR 700/850 Dual Control | 3,790 | 6,555 | 1,170 | 1,595 | 2,770 | 4,490 | 1,705 | 2,215 | 2,665 | 745 | 885 | 940 | 13.6 |

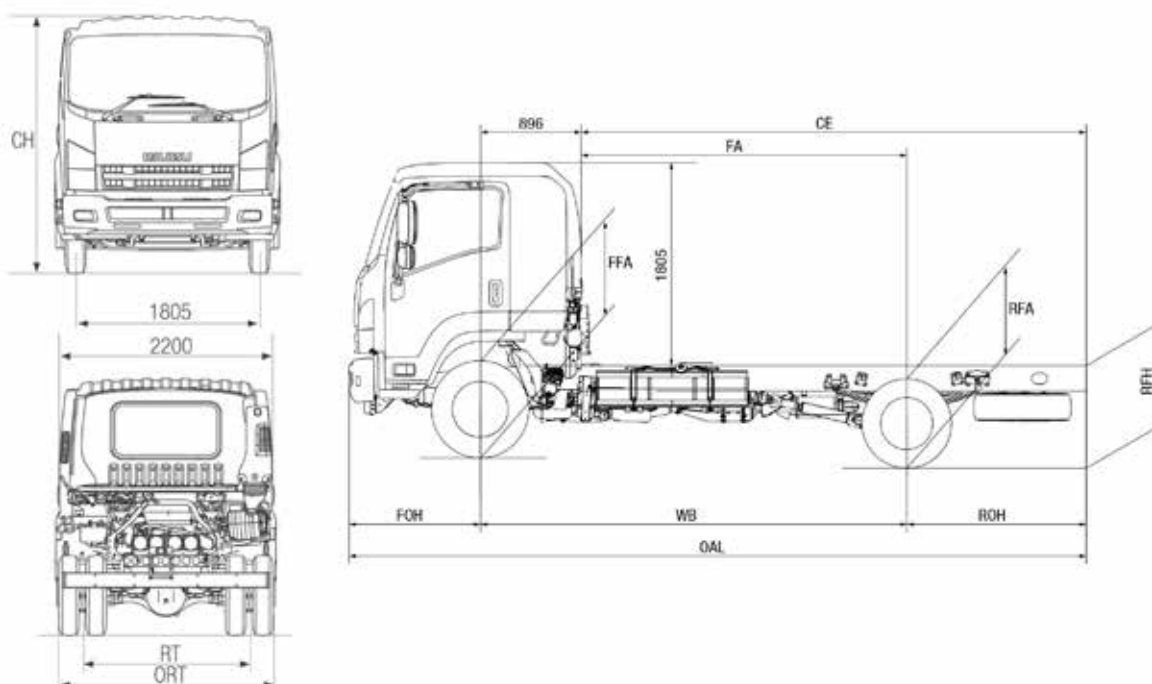

PERFORMANCE (calculated - typical paved road)

| | | Geared Speed* (top gear at peak power engine RPM) | Low Speed Gradeability (lowest forward gear assuming no wheel slip) | Engine Speed (top gear at 100km/h) |
|----------------------|------------------|--|--|---------------------------------------|
| FSR 700 Dual Control | At 12,000 kg GVM | 122 km/h @ 2,400 RPM | 34% | 1,965 RPM |
| FSR 850 Dual Control | At 14,000 kg GVM | 122 km/h @ 2,400 RPM | 29% | 1,965 RPM |

* Maximum speed achievable depends on vehicle frontal area as well as other factors. Consult your Isuzu dealer for more detailed information. FSR 850 models speed limited to 100km/h.

ISUZU WARRANTIES

STANDARD¹

New Vehicle 3 years • 150,000km • 2,500 hours

Cab Perforation Corrosion 3 years • unlimited kms

Isuzu Assist: 24 hour roadside assistance (3 years, unlimited kms)*

EXTENDED CARE²

Extended Warranty: 5 years • 300,000km • 5,000 hours

Isuzu Assist: 24 hour roadside assistance (5 years, unlimited km's)

ORDER CODES

| Model | Code |
|--------------------------|--------------|
| FSR 700/850 Dual Control | FH-FSRSF-K14 |

¹ Subject to the conditions outlined in the IAL New Vehicle Warranty, the Isuzu FSR models carry a standard factory warranty which covers the owner: (i) for the entire vehicle, for the first 36 months or 150,000 km or 2,500 hrs (whichever comes first). (ii) against cab perforation corrosion, for 36 months and unlimited kilometres. ² Extended Warranty as illustrated may be purchased to cover the owner against the failure of original components, but may exclude some components and expendable items such as oil, filters, etc. *Valid for three years from the date of new vehicle purchases. All Isuzu warranties are subject to mandatory prescribed terms under Australian Consumer law including customer guarantees. For more details visit the Isuzu website which explains Isuzu warranties in more detail, or alternatively contact your local dealer. All warranties commence from date of delivery.

ISUZU AUSTRALIA LIMITED ABN 97 006 962 572 ("IAL"). The information in this spec sheet was correct at time of printing, but all measurements, specifications and equipment are subject to change without notice. Some equipment may have been changed and/or is available at extra cost. IAL may make changes at any time without notice, in prices, colours, materials, equipment and models. IAL makes all reasonable attempts to ensure the availability of all vehicles and equipment. The information in this spec sheet is general in nature. Your Isuzu dealer can confirm all measurements, specifications and vehicle / equipment availability upon request. To the extent permitted by the law, IAL is not liable to any person as result of reliance on the content of this spec sheet.

December 2015, ARK0882

We
share
the
load.

ISUZU
RELIABILITY IS EVERYTHING