



Model: GVR
GVM: 16,000kg
GCM: 32,000kg
Engine type: Isuzu SiTEC 270
Displacement: 9839cc
Power: 199kW @ 2200rpm
 1,000Nm @ 1500rpm

GVR PRIME MOVER

Cab/Chassis specification as at January 1999.
RGS/IGM2707

CABIN SPECIFICATIONS AND APPOINTMENTS

CAB EXTERIOR

- All steel cab with welded strengthening ribs and side door impact beams. Torsion bar assisted cabin tilt to 45°.
- Four point cabin suspension utilising silicone filled rubber isolators.
- Cation electrodeposition primer.
- Heavy duty bumper bar with step holes and footplate.
- Halogen headlamps, hinged for easy bulb replacement.
- Park lamps and cabin clearance lamps.
- Turn signal lamps in front bumper and over wheel arches.
- 2 speed windscreen wiper / washer system with variable intermittent mode. Triple washer jets mounted on wiper arms.
- Tinted and laminated windscreen. Tinted and toughened side and rear glass.
- 'West Coast' type rear view mirrors.
- Alloy, non-slip cabin entry steps.
- Lift-up front panel for access to clutch and windscreen washer fluids without tilting the cabin. Engine fluid check points at rear of cabin.

CAB INTERIOR

- Fully trimmed cab interior with cloth seat facings, formed roof lining. Overhead storage lockers. Driver and passenger sun visors.
- Pull out drinks holder in centre fascia, cigarette lighter (24 volt). Ash trays in doors.
- Isringhausen ISRI 6500/517 air suspension driver's seat with auto weight adjustment to 130kg. Height, rake and back rest recline adjustment. Pneumatic lumbar support.
- Outboard reclining passenger seat with under seat storage drawer. Folding centre seat back with lockable compartment and tray.
- Outboard lap/sash seat belts with emergency locking retractors, centre lap seat belt.
- Tilt/telescopic adjustable steering column with single release lever. Soft feel urethane steering wheel with zero offset to driver's seat.
- Easy entry grab handles on 'A' and 'B' pillars.
- Heater demister with 4 speed fan, 4 outlet vents to screen, 5 fascia outlets, 5 foot outlets, demister ducts to door glass.
- Optional fully intergrated air conditioning.
- Eurovox AM/FM radio cassette with digital clock, dash mounted. Remote seek/volume and mute switch located on dash to right of steering wheel.
- DIN standard aperture in dash for CB radio.
- 12 Volt /100W cigarette lighter type electrical socket located in centre console.
- 24 Volt - 2 pin accessory plug in centre console.
- Park brake activation lever at left side of driver's seat.
- Combination passenger-side dash storage tray/fuse panel cover.
- Interior rear vision mirror.
- Passenger side assist grip.
- Driver's left foot rest.
- Exhaust vents rear/upper cab.
- Business card clip. Coat hook at rear of cab.
- Elastic mesh pocket on driver's door.

CONTROLS

- Left side combination stalk switch for exhaust brake, windscreen wipers and washer, hazard lamps.
- Right side combination stalk switch for headlamps, high beam and turn signals.
- Engine idle speed adjust control.
- Key operation for engine start and stop, external engine crank switch for service when cab is tilted.
- 3 way switch for interior lamp activated by driver and passenger doors.
- Trailer brake controls with brake lines to rear of cab

INSTRUMENTATION

- GAUGES:** Speedometer, odometer, trip meter and tachometer. Gauges for coolant temperature, fuel level and brake air pressure.
- WARNING LAMPS:** With warning bulb check switch. Battery charge, oil pressure, low air pressure, brake system, stop and tail light failure.
- INDICATOR LAMPS:** Turn signals, parking brake on, high beam on, exhaust brake engaged. Reversing lamp and beeper.

TOOLS

- Lockable tool box. 10,000kg capacity jack and wheel changing tools, tool kit.

MODEL RATINGS AND DIMENSIONS

MODELS	RATINGS		TARE MASS [#]			DIMENSIONS (mm)								TURNING CIRCLE [*]	
	GVM	GCM	TOTAL	FRONT	REAR	WB	OAL	ROH	CA	CE	FFH UNLADEN	FFH LADEN	RFH UNLADEN	RFH LADEN	KERB TO KERB
GVR	16,000kg	32,000kg	4,840kg	2,935kg	1,905kg	3,400	5,640	970	2,690	3,410	985	935	1,050	985	13.9m

[#] Estimated mass of cab/chassis with oil, water and fuel tank containing 10 litres of fuel and excluding spare wheel and tools.

^{*} Subject to weight distribution

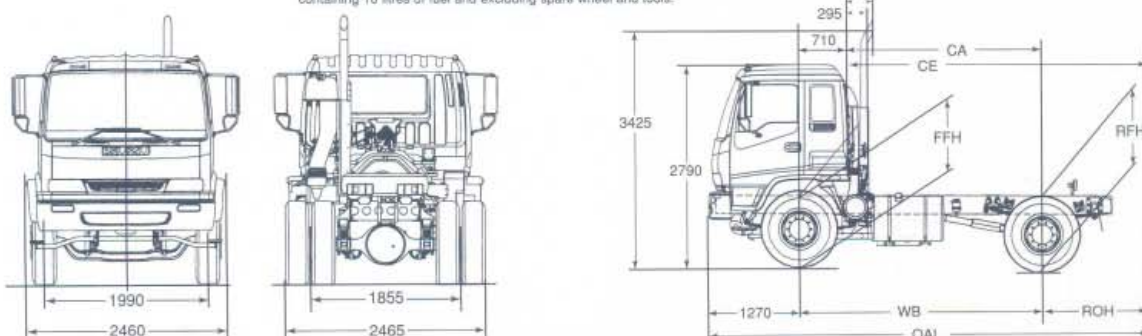

For further information regarding Cab/Chassis dimensions your Isuzu Dealer can access detailed Body Builders diagrams from the Isuzu Truck Data Manual.

DRIVELINE SPECIFICATIONS

ENGINE: ISUZU SITEC 270

Isuzu 6SD1-TC 6 cylinder in line, overhead camshaft, four stroke, direct injection, diesel. Turbocharged and Air-To-Air Intercooled.

BORE X STROKE: 120 mm x 145 mm.

DISPLACEMENT: 9839 cc.

COMPRESSION RATIO: 16.5 : 1.

POWER: 199 kW @ 2200 RPM. (ISO 1585)

TORQUE: 1,000 Nm @ 1500RPM. (ISO 1585)

COOLING SYSTEM

- 6 blade plastic cooling fan 600 mm diameter with bell-mouth fan shroud and dual drive belts.
- Bimetallic controlled, thermatic fan clutch.
- Tube and corrugated fin, pressure type radiator. Dimensions: 800 mm x 636 mm x 54 mm. Frontal area 5,088 cm².
- Coolant capacity 29.0 litres.

AIR INTAKE SYSTEM

- Donaldson 13" diameter, dry element, two stage filter. Vertical intake stack with rain head.
- Turbocharger and Air-To-Air Intercooler. Intercooler dimensions: 540 mm x 470 mm x 53 mm. Total intercooler frontal area 2,540 cm².

EXHAUST SYSTEM

- Horizontal exhaust muffler with vertical exhaust pipe.
- Air controlled, butterfly type exhaust brake.

FUEL SYSTEM

- In line plunger, Bosch 'AP' type fuel injection pump with 'RLD' mechanical all speed governor.
- Electronic road speed limiter.
- In line, paper element filter, see through water separator with drain cock.
- Single 400 litre rectangular aluminium fuel tank.

TRANSMISSION**EATON FS-8209 9 speed direct drive**

- 8 synchronised, regular usage forward speeds. One forward crawler speed, 1 reverse speed.. Oil capacity 8.5 litres.
- 'Repeat-H' shift pattern. Pre-selected and synchronised range change.
- Gear ratios to 1:

Low	1st	2nd	3rd	4th
12.64	8.81	6.55	4.77	3.55
Rev	5th	6th	7th	8th
13.21	2.48	1.85	1.34	1.00

- Maximum geared speed 110 km/h.
- Electronically road speed limited to 100km/h

CLUTCH

- Hydraulic control dry single plate with cushioning springs. Coil type pressure springs. Asbestos free lining material.
- Clutch disk diameter 381 mm (15") diameter.
- Total lining area (both sides) 1363 cm².

FRONT AXLE

ISUZU F063 CAPACITY 6300KG

- Reverse Elliot I-beam type. King Pin diameter 50 mm with cylindrical roller thrust bearing.
- Oil bath lubricated front wheel hubs with see-through oil level indicator.

REAR AXLE

MERITOR RS-23-160G CAPACITY 10,500KG

- Banjo type, fully floating, single reduction.
- Rear Axle Ratio: 4.300: 1
- Hypoid type ring gear, 457 mm diameter. Oil capacity 15.0 litres.

CHASSIS SPECIFICATIONS

CHASSIS FRAME

- Parallel rail, ladder type, channel section, cold riveted.
- Straight frame for easy body mounting. 850 mm frame width.
- Rear crossmember and spring hanger brackets bolted to frame allowing easy wheelbase modification.
- Frame side member dimensions: 258 mm x 85 mm x 10 mm.
- Frame reinforcement angle section: 224 x 77 x 4.5 mm 'L' section (cab back). 224 x 77 x 6.0 mm 'L' section (rear axle).
- Frame material: SAPH440 weldable mild steel.
- Cut and tapered rear frame.
- Trailer air and electrical connectors to rear of cab.

SUSPENSION

Semi-elliptical, alloy steel tapered multi-leaf springs. Fully wrapped eye with greasable shackles.

FRONT

- 1470mm x 80mm x 11mm x 9 leaves.
- Hydraulic, double acting, telescopic shock absorbers.

REAR

- Main: 1420 x 100mm x 11mm x 7 leaves
1420 x 100mm x 10mm x 1 leaf
- Aux: 980 x 100mm x 9mm x 7 leaves
- Hydraulic, double acting, telescopic shock absorbers.
- Stabiliser bar.

BRAKES

- Meritor 'Q-Plus' full air, 'S'-cam, dual circuit brake system with front and rear leading and trailing shoes. Asbestos free brake shoe lining material.
- Drum diameters (front and rear): 419 mm.
- Brake drum swept areas: 8,688 cm² total: 4,002 cm² front, 4,686 cm² rear.
- Air tank capacity: 67.5 litres
- Air dryer.
- Nylon brake air tubing.
- Spring park brake acting on rear wheels with 11.0 litre tank.
- Air controlled, butterfly type exhaust brake.
- L.S.P.V. for prime mover brakes.

STEERING

- Fully integral power assisted recirculating ball and nut type.
- Gear ratio 22.4 : 1. Turns lock to lock 4.5.
- Gear driven vane type oil pump. See-through oil reservoir. Oil capacity 2.5 litres (inc. reservoir).

WHEELS AND TYRES**WHEELS**

- 8.25 x 22.5, 10 stud ISO standard (hub piloted) disc wheels. Stud size: 22mm. Offset: 165mm.
- Number of wheels and tyres 7, including spare. Note: Spare wheel carrier not supplied.

TYRES

- 11R22.5 148/145L tubeless radial tyres front and rear.
- Type: Michelin XZE1 (Front and Spare)
Michelin XDE1 (Rear)
- Load and speed ratings per tyre:
3150kg (single) / 2900kg (dual) / 120 km/h

ELECTRICAL SYSTEM

- Batteries - 2 x 12 volt / 65 amp/h, negative earth.
- Alternator - 24 volt / 40 amp.
- Starter motor - 24 volt / 4.5 kW.
- Rear stop and tail lamps and licence plate lamp with long leads for variable body mounting.

ISUZU NEW TRUCK WARRANTIES

Subject to the conditions outlined in the I-GM New Vehicle Warranty, the Isuzu GVR model carries a standard factory warranty which covers the owner: (i) for the entire vehicle, for the first 24 months or 150,000km (whichever comes first) (ii) for the powertrain, which runs concurrently for 36 months or 200,000km (whichever comes first) (iii) against cab corrosion, for 36 months and unlimited kilometres.

A TruckPower Extended Warranty is available by purchase to cover the owner against the failure of original components, but excludes some components and expendable items such as oil, filters, etc. Three variations of the Extended Warranty are available: 36 months or 200,000km, 48 months or 300,000km and 60 months or 350,000km. Please consult with your Isuzu Dealer for full details obtainable from a dedicated brochure available to customers.

ISUZU-GENERAL MOTORS AUSTRALIA LTD A.C.N. 006 962 572. PLEASE NOTE: as the policy of I-GM is one of continual product improvement, all specifications and equipment are subject to change without notice. No I-GM dealer or other person is authorised or permitted to give or make any statement, assertion or undertaking in relation to the quality, performance, characteristics, descriptions or fitness for any purpose of any I-GM product or in connection with the supply of any I-GM product which is at variance with any written statement, assertion or undertaking on any of these subjects given or made by I-GM in its published sales literature, and the company accepts no liability for any such unauthorised action. I-GM has franchised dealers in many parts of Australia, for the sale of service, parts and the provision of service to the owners of I-GM products. Every endeavour is made to ensure that such dealers carry adequate stocks of service parts and are equipped to provide satisfactory service, but makes no promise, other than that contained in the I-GM new vehicle warranty, that such parts or service facilities will be available or available at any specific location or at any particular time. A word about this specification sheet. We have tried to make it as comprehensive and factual as possible. However, since the time of printing some of the information you will find here may have been updated. Also, some of the equipment shown or described through this specification sheet may have been changed and/or is available at extra cost. And the right is reserved to make changes at any time without notice, in prices, colours, materials, equipment and models. Your I-GM dealer has details and before ordering, you should ask him/her to bring you up to date.

ISUZU
RELIABILITY IS EVERYTHING